

## Barrel cortex function

Dirk Feldmeyer<sup>a,b,c</sup>, Michael Brecht<sup>d</sup>, Fritjof Helmchen<sup>e</sup>, Carl C.H. Petersen<sup>f</sup>, James F.A. Poulet<sup>g,h</sup>, Jochen F. Staiger<sup>i</sup>, Heiko J. Luhmann<sup>j</sup>, Cornelius Schwarz<sup>k,l,\*</sup>

<sup>a</sup> Forschungszentrum Jülich, Institute of Neuroscience and Medicine, INM-2, D-52425 Jülich, Germany

<sup>b</sup> RWTH Aachen University, Medical School, Department of Psychiatry, Psychotherapy and Psychosomatics, D-52074 Aachen, Germany

<sup>c</sup> JARA – Translational Brain Medicine, Aachen, Germany

<sup>d</sup> Bernstein Center for Computational Neuroscience, Humboldt University Berlin, Philippstr. 13, D-10115 Berlin, Germany

<sup>e</sup> Department of Neurophysiology, Brain Research Institute, University of Zurich, Winterthurerstrasse 190, CH-8057 Zurich, Switzerland

<sup>f</sup> Laboratory of Sensory Processing, Brain Mind Institute, Faculty of Life Sciences, Ecole Polytechnique Federale de Lausanne (EPFL), Lausanne, Switzerland

<sup>g</sup> Max-Delbrück-Centrum für Molekulare Medizin (MDC), Robert-Rössle-Str. 10, Berlin, Germany

<sup>h</sup> Neuroscience Research Center and Cluster of Excellence NeuroCure, Charité-Universitätsmedizin, D-13092 Berlin, Germany

<sup>i</sup> Department of Neuroanatomy, Center for Anatomy, Georg-August-University Göttingen, Kreuzberggring 36, D-37075 Göttingen, Germany

<sup>j</sup> Institute of Physiology and Pathophysiology, University Medical Center Mainz, Duesbergweg 6, D-55128 Mainz, Germany

<sup>k</sup> Systems Neurophysiology, Werner Reichardt Centre for Integrative Neuroscience, Eberhard Karls University, D-72070 Tübingen, Germany

<sup>l</sup> Department of Cognitive Neurology, Hertie Institute for Clinical Brain Research, Eberhard Karls University, D-72070 Tübingen, Germany

### ARTICLE INFO

#### Article history:

Received 22 December 2011

Received in revised form 28 October 2012

Accepted 12 November 2012

Available online 27 November 2012

#### Keywords:

Barrel cortex  
Connections  
Microcircuitry  
Columnar organization  
Network activity  
Neuromodulation  
Acetylcholine  
Behavior  
Perception  
Development  
Rodent

### ABSTRACT

Neocortex, the neuronal structure at the base of the remarkable cognitive skills of mammals, is a layered sheet of neuronal tissue composed of juxtaposed and interconnected columns. A cortical column is considered the basic module of cortical processing present in all cortical areas. It is believed to contain a characteristic microcircuit composed of a few thousand neurons. The high degree of cortical segmentation into vertical columns and horizontal layers is a boon for scientific investigation because it eases the systematic dissection and functional analysis of intrinsic as well as extrinsic connections of the column. In this review we will argue that in order to understand neocortical function one needs to combine a *microscopic* view, elucidating the workings of the local columnar microcircuits, with a *macroscopic* view, which keeps track of the linkage of distant cortical modules in different behavioral contexts.

We will exemplify this strategy using the model system of vibrissal touch in mice and rats. On the macroscopic level vibrissal touch is an important sense for the subterranean rodents and has been honed by evolution to serve an array of distinct behaviors. Importantly, the vibrissae are moved actively to touch – requiring intricate sensorimotor interactions. Vibrissal touch, therefore, offers ample opportunities to relate different behavioral contexts to specific interactions of distant columns. On the microscopic level, the cortical modules in primary somatosensory cortex process touch inputs at highest magnification and discreteness – each whisker is represented by its own so-called barrel column. The cellular composition, intrinsic connectivity and functional aspects of the barrel column have been studied in great detail.

Building on the versatility of genetic tools available in rodents, new, highly selective and flexible cellular and molecular tools to monitor and manipulate neuronal activity have been devised. Researchers have started to combine these with advanced and highly precise behavioral methods, on par with the precision known from monkey preparations. Therefore, the vibrissal touch model system is exquisitely positioned to combine the microscopic with the macroscopic view and promises to be instrumental in our understanding of neocortical function.

© 2012 Elsevier Ltd. All rights reserved.

\* Corresponding author at: Werner Reichardt Institute for Integrative Neuroscience, University Tübingen, Otfried Müller Str. 25, D-72076 Tübingen, Germany. Tel.: +49 7071 29 80462; fax: +49 7071 29 25011.

E-mail address: [cornelius.schwarz@uni-tuebingen.de](mailto:cornelius.schwarz@uni-tuebingen.de) (C. Schwarz).

## Contents

1. Introduction	4
2. The microscopic view: Columnar microcircuitry	5
2.1. Development of the cortical barrel column	5
2.2. Ascending pathway and cortical map	7
2.3. Columnar excitatory connections	8
2.4. Columnar inhibitory connections	9
2.5. Columnar network dynamics and receptive field properties	11
2.6. Perceptual functions of the barrel column	12
2.7. Conclusions: Microscopic view	13
3. The macroscopic view: Associative context	15
3.1. Specific vs. general contexts: Associative coupling vs. brain states	15
3.2. Long-range connections	15
3.2.1. Direct cortico-cortical projections	15
3.2.2. Cortico-thalamic loops	16
3.2.3. Cortico-subcortical loops	17
3.2.4. Neuromodulatory systems	17
3.3. Transcolumnar processing	17
3.4. Studying associative coupling using whisking behavior	19
4. Combining the microscopic and macroscopic view. The need to study relevant sensorimotor or cognitive behavior	19
Acknowledgements	21
References	21

## 1. Introduction

Elucidating the function of cortical networks requires an interplay between anatomical and physiological analyses, as has been emphasized repeatedly by earlier reviews of cortical function (e.g. Douglas and Martin, 2007; O'Connor et al., 2009). Such an interactive approach will provide mechanistic ideas 'how' the cortical machinery might work. However, in order to decide between different mechanistic hypotheses of cortical function the question of 'what' is achieved by cortical processing will become increasingly important. For sensory systems this question is asked by studies on the physiology of perception (Parker and Newsome, 1998), involving simultaneous measurement of neuronal activity and the subject's behavior and percept.

So, what is the genuine function of the cerebral cortex? A traditional way to approach this question is to measure how neocortical circuits are involved in signal processing. The best way to do that is to investigate sensory systems, because the physical stimulus leading to activation of the cerebral cortex can be brought under tight experimental control. Measurement of neocortical information about a stimulus that we control precisely, may tell us something about the capability of the neocortex to process and to respond to this specific sensory input. The problem with this approach is that sub-cortical structures typically contain much more quantifiable stimulus information than the cerebral cortex. The conclusion from this has been that neocortical circuits either lose information, or at least represent it using highly intricate (e.g. nonlinear) ways (Wu et al., 2006). An alternative idea, however, is that sensory cortex is not mainly processing details of its inputs via ascending sensory pathways, but represents information about what else is going on in the brain. This tendency increases when going from sensory to associative cortical areas. Maybe the genuine cortical function has less to do with signal processing itself (in the narrow sense of the word; like the process needed to extract relevant sensory information from the output of sensory receptors), but rather with the proper organization and use of information in view of the demands and constraints of the specific situation the subject is in. This notion entails that it is the main function of neocortical processes to put externally and internally generated signals in context to allow for flexible goal-oriented behavior. In a second step, repeated processing within the same

context leads to the learning of the respective behavior – possibly laid down as memory traces in cortical circuits (Fuster, 2009).

The view that associative and mnemonic aspects are at the core of neocortical function may solve the puzzle why cortical microcircuitry is similar across areas and species although so many different kinds of signals are dealt with (reaching from sensation via cognitive processing to motor functions). It is intuitive to assume that signal processing (again in the narrow sense of the word) is not done by the generalist neocortical neuronal architecture, but is often relayed to dedicated sub-cortical neuronal structures – an idea that is supported by the fact that every neocortical area is connected to many of them – often in a reciprocal manner (Felleman and van Essen, 1991; Diamond et al., 2008). In this framework, investigating neocortical function would not make much sense if the cerebral cortex is isolated physically, anesthetized or investigated in a highly rarefied experimental situation (e.g. probing it with point like stimuli). Rather, for a genuine understanding of neocortical function, its activity has to be probed in a behaving subject solving a task in an environment that offers a minimum of (experimentally controlled) contextual dependencies. Employing complex stimuli that show temporal and/or spatial contingencies that require contextual processing is a good start. Even better is to probe neocortical activity in different, meticulously controlled sensorimotor or cognitive situations.

All this would be well and good – were the neocortical structure and circuits not so complex. One column spanning a surface area of approximately  $300\ \mu\text{m} \times 300\ \mu\text{m}$  consists of some 10,000 neurons, composed of excitatory and inhibitory neurons, organized in different layers and with characteristic input and output connections (Lübke and Feldmeyer, 2007; Schubert et al., 2007; Lefort et al., 2009; Oberlaender et al., 2011b). An understanding of this complexity calls for very different types of experiments than the ones depicted in the last paragraph, namely highly precise analysis of neuronal morphology, connectivity and synaptic function – best performed in isolated preparations like neocortical slices or anesthetized *in vivo* preparations.

The conceptual and technical challenge to understand the function of the neocortex thus involves on one side a 'macroscopic' view of context dependencies and on the other a 'microscopic' view on the mechanisms of population, cellular, sub-cellular and

### Abbreviations list

#### Substances, Methods:

GECI genetically-encoded calcium indicators  
VSD voltage sensitive dyes

#### Transmitters

GABA gamma amino butyric acid  
5HT serotonin  
ACh acetylcholine  
NE norepinephrine

#### Brain structures

TG, SA, RA trigeminal ganglion, slowly and rapidly adapting afferents  
TN trigeminal nuclei  
PrV trigeminal nucleus principalis  
SpV, SpVo, SpVi, SpVc trigeminal nuclei spinalis, oralis, interparialis, caudalis  
VPM, VPL ventero-posterior-medial, ventero-posterior-lateral thalamus  
POm posterior thalamus, medial part  
M1 primary motor cortex  
V1, V2, V3 primary, secondary, tertiary visual cortex  
S1, S2 primary, secondary somatosensory cortex  
PV, PM, PL parietal-ventral, parietal-medial, parietal-lateral cortical areas  
L1, L2/3, L4, L5, L6 cortical layers

#### Inhibitory cells

PV parvalbumin expressing cells  
SST somatostatin expressing cells  
5HT3aR serotonin receptor 5HT3a expressing cells  
FS fast spiking cells  
NFS non-fast spiking cells

#### Behavioral elements

CS conditioned stimulus  
US unconditioned stimulus

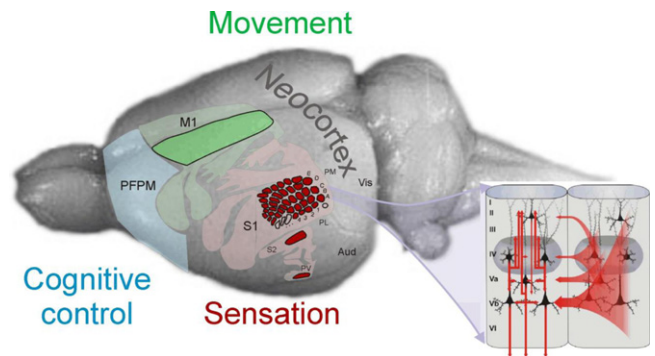

**Fig. 1.** The study of microscopic and macroscopic levels using the barrel cortex as a model system. The microscopic barrel column circuitry is very well studied. The blow up of the barrel cortex circuit diagram on the right (taken from Schubert et al., 2007) shows the richness of intra- and transcolumnar cortical connections which outnumber by far the topographically-ordered, layer-specific thalamic inputs. The macroscopic level can be studied as sensorimotor integration needed to guide and optimize active discrimination. The neuronal correlate is highly accessible and is provided by the embedding of whisker related touch representations in unimodal primary and secondary somatosensory cortex (S1, S2), as well as association somatosensory cortices PV, PL, PM. Whisker movement is processed by association of primary motor cortex, and cognitive processes affecting whisker-related active touch can be studied in the prefrontal/premotor cortical areas (PPFM). Whisker representations are highlighted.

be easily combined with approaches to record neuronal data on the cellular and molecular level using e.g. genetic modifications, single cell recordings and cellular imaging. Most recently, such high-resolution recordings have been increasingly obtained in awake animals during behavior. Thus, the rodent whisker-to-barrel cortex pathway is an excellent system in which questions about 'how' and 'what' of sensory information processing can be asked together using the same animal in the same experimental context.

The aim of this review is to give a comprehensive and state-of-the-art overview of how these questions are currently addressed with a focus on the primary somatosensory area, the rodent barrel cortex. We will start in Section 2 with an overview of the 'microscopic', column-centered view. This section will discuss the cortical microcircuit with a short excursion to its development, and detail columnar activity and its relationship to vibrissa-related perception. Section 3 will portray vibrissal active touch as a system that supports a rich repertoire of behaviors in rodents. It will cover the neuronal correlate of associative coupling: maps, long-range projections and trans-columnar processing. We will end with recent advances to measure different vibrissa-related behaviors and its context using advanced and precise behavioral methods in head-fixed rodents. We conclude by giving an outlook on possible future developments for the elucidation of cortical function.

## 2. The microscopic view: Columnar microcircuitry

### 2.1. Development of the cortical barrel column

molecular signal processing. Mostly, these two aspects have been investigated separately in different types of experiments. Is it possible to control local mechanistic and global behavioral parameters together in one experiment? Technological developments of the last decade have shifted this type of experiment from the realm of dreams to feasibility. First experiments combining genetic manipulation with cellular imaging employed in animals trained to perform sophisticated behavior have been conducted (Harvey et al., 2012) and optogenetic stimulation has been used for a detection task (Huber et al., 2008).

The rodent whisker-related tactile system with its exquisite modular, cortical representation is an ideal model to study the structure-function relationship of a well-defined local cortical network and its development during early ontogenetic stages (Fig. 1) (for reviews see Brecht, 2007; Lübke and Feldmeyer, 2007; Petersen, 2007; Schubert et al., 2007; Fox, 2008; Kanold and Luhmann, 2010). Together with the primate, cat and, more recently, mouse visual system, the rodent whisker-related tactile system is one of the best studied sensory model systems, with relatively large amounts of data on cell properties and synaptic connectivity already available. It has the additional advantage to

The whisker-related barrel column is – together with columns in visual cortex of cats and monkeys – the best understood model system of cortical microcircuitry. Knowledge about its development may contribute important aspects needed to understand its mechanisms of operation in the adult, both under physiological as well as pathophysiological conditions, such as neurodevelopmental disorders (for review Amaral et al., 2008; Courchesne et al., 2007). Before we discuss the details of the mature circuit we will therefore take a short deviation into important developmental aspects. The development of the neocortex is regulated by an intricate interplay between genetic factors and spontaneous and evoked neuronal activity. Arealization, the initial division of the

cerebral cortex into areas during prenatal development, is essentially controlled by genes and proceeds independent from electrical activity (for review see Rash and Grove, 2006). For instance, ectopic expression of the fibroblast growth factor 8 leads to a partial duplication of the barrel field (Fukuchi-Shimogori and Grove, 2001). The subsequent formation of early cortical circuits, however, is in many aspects regulated by spontaneous and periphery-driven neuronal activity and by the influence of neuromodulatory systems (Khazipov and Luhmann, 2006; Allene and Cossart, 2010). These effects are relayed to the developing cortical circuitry by the subplate, a layer of early-born GABAergic and glutamatergic neurons, which show mature functional properties (for reviews see Sur and Leamey, 2001; López-Bendito and Molnár, 2003; Kanold and Luhmann, 2010) and are receptive to acetylcholinergic neuromodulation (Dupont et al., 2006; Hanganu et al., 2009) (Fig. 2 upper panel). At birth, the subplate mediates spindle bursts and gamma oscillations to the cortical plate (Khazipov et al., 2004; Minlebaev et al., 2007; Yang et al., 2009; Minlebaev et al., 2011). Interestingly, these subplate-driven events are dependent on electrical synapses and synchronize local neuronal networks of 200–400  $\mu\text{m}$  in horizontal dimension, thus constituting cortical ‘pre-columns’ or ‘neuronal domains’ (Yang et al., 2009; Yuste et al., 1992; Dupont et al., 2006; Sun and Luhmann, 2007). The prominent network activity present during early corticogenesis also controls programmed cell death (for review (Kilb et al., 2011), such as caspase-3 mediated apoptosis, by activating cell survival (e.g. neurotrophic factors) or cell death pathways (Golbs et al., 2011; Heck et al., 2008; Nimmervoll et al., 2012; Wagner-Golbs and Luhmann, 2012). During this early postnatal period, layer 4 in rat barrel cortex shows prominent activity-dependent plasticity to whisker plucking with an expansion of the cortical representation responding to the spared whisker (for review Fox, 2002) (Fig. 2 lower panel). At the end of the first postnatal week the activity pattern changes into massive, large scale synchronous activity patterns that appear independent from the subplate (Golshani et al., 2009). At that age layer (L) 4 plasticity has diminished and predominantly occurs in L2/3 and L5 (Diamond et al., 1994; Fox, 1992). The expansion of the cortical representation of spared whiskers into the representation of adjacent deprived whiskers is mediated by a weakening of the deprived input and a strengthening of the spared input (for review see Feldman and Brecht, 2005).

A third, rather drastic change of cortical activity pattern then occurs during the second and third postnatal week when the network firing is greatly reduced and decorrelated, and thus approaches the characteristic firing patterns of the adult network (Maravall et al., 2004a,b; Golshani et al., 2009). One causal factor for reduction and decorrelation of firing appears to be the upregulation of  $\text{K}^+$  channel expression and the concomitant decrement of input resistance of pyramidal cells (Kang et al., 1996; Maravall et al., 2004b; Waters and Helmchen, 2006; Golshani et al., 2009). Another contributing factor is the developmental shift of GABAergic synaptic function from excitatory to inhibitory action (for review Ben-Ari et al., 2012). Excitatory GABAergic synapses contribute initially to synchronized network activity (Owens and Kriegstein, 2002; Daw et al., 2007), but at the beginning of the second postnatal week shift to inhibitory action (Luhmann and Prince, 1991; for review see Kilb, 2011). At the same time the number of glutamatergic synaptic connections increases dramatically and become more reliable and efficacious (Frick et al., 2007; Feldmeyer and Radnikow, 2009). Thus, the end of the second postnatal week sees a major reshuffling of the balance between excitation and inhibition in the columnar network, with the effect of low frequency decorrelated firing and the establishment of the rapid feed-forward inhibitory action in L4 characteristic of the mature columnar circuit.

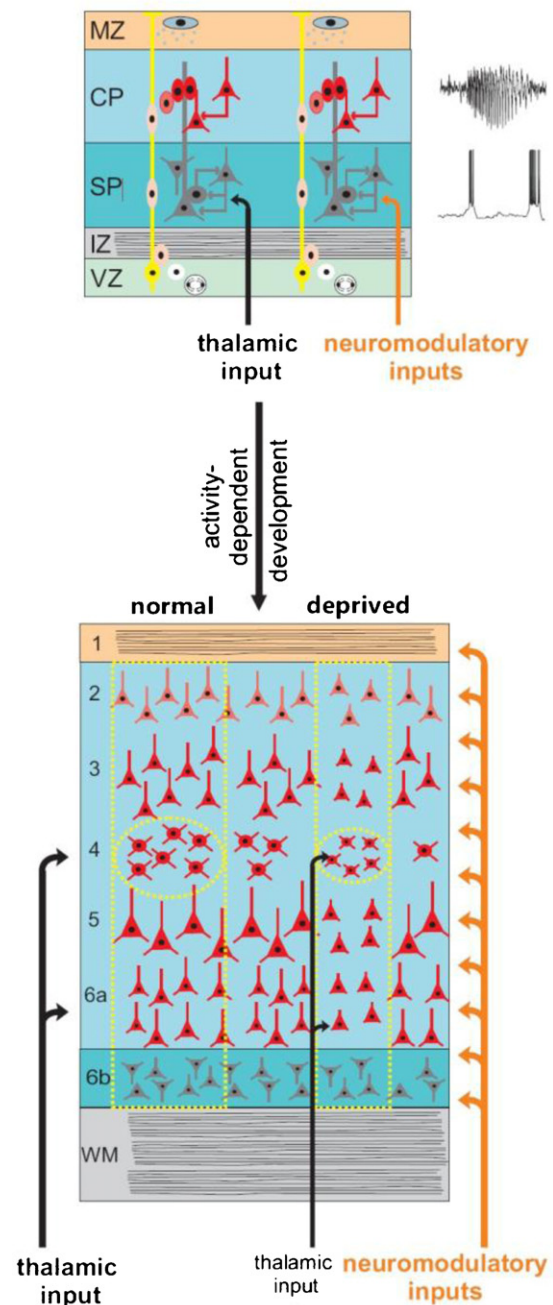

**Fig. 2.** Model of activity-dependent development of cortical columnar networks. During prenatal stage the cerebral cortex consists of (i) the marginal zone (MZ, later L1) with Cajal-Retzius neurons releasing the extracellular matrix protein reelin, (ii) the cortical plate (CP, later L2 to L6a) with immature neurons migrating vertically along radial glial cells (yellow) and tangentially into the cortex, (iii) the subplate (SP, later L6b in rodents) with GABAergic and glutamatergic neurons densely connected via electrical and chemical synapses, (iv) the intermediate zone (IZ, later white matter) and (v) the neurogenic ventricular zone (VZ). At early stages of cortical development, the subplate is selectively innervated by thalamic and neuromodulatory, e.g. cholinergic, inputs, which elicit burst discharges in subplate neurons (single cell burst recording right of SP). These bursts are amplified in the subplate via electrical and chemical synapses and transmitted into the cortical plate, where they elicit local synchronized network bursts (field potential recording right of CP), which resemble in their spatial dimensions a barrel-related cortical column. For details see (Luhmann et al., 2009; Kanold and Luhmann, 2010). During early postnatal development the cortical columnar network is refined in an activity-dependent manner. Sensory deprivation induces structural and functional modifications such as shrinkage of the deprived column, enhanced cell death, reduced dendritic and axonal extensions or weakening of the thalamic input (for details see Section 2.1).

Neuromodulatory systems play a special role in the development and shaping of cortical microcircuits, particularly the cholinergic system. At P0, this cholinergic input is confined to the cortical subplate (Hanganu and Luhmann, 2004; Dupont et al., 2006; Hanganu et al., 2009), where it causes a pronounced excitation and burst firing of subplate cells (for reviews see Luhmann et al., 2009; Kanold and Luhmann, 2010) (Fig. 2, upper panel). With further development and in rodents until the end of the first postnatal week, cholinergic fibers have innervated all cortical layers (Mechawar and Descarries, 2001) (Fig. 2, lower panel). Acetylcholine release is crucial for the emergence of the barrel pattern in immature neocortex (Zhu and Waite, 1998; Zhu et al., 2002) and keeps an important role for experience-dependent functional plasticity in the mature columnar network (Ego-Stengel et al., 2001; Ramanathan et al., 2009). Likewise monoaminergic innervations play important roles in barrel formation (for review see Gaspar et al., 2003).

Sensory inputs are needed to shape the details of the microcircuit in rodent barrel cortex during a critical period around P10 to P14. At this time the basic morphological features of neurons in barrel cortex are fairly well established (Zhu, 2000), but restructuring on a fine scale, e.g. higher-order branching of basal dendrites in L2/3 neurons and dendritic spine motility (Lendvai et al., 2000; Maravall et al., 2004a), or pruning of thalamocortical axons in their final termination area in L4 of a single barrel (Bender et al., 2003; Harris and Woolsey, 1983; Lübke et al., 2000; Schubert et al., 2003; Staiger et al., 2004) are still prominent and are strongly affected by whisker deprivation (cf. compare normal and deprived column in Fig. 2 lower panel). Thus, sensory inputs lead to experience-dependent refinements of the detailed cell morphology, connectivity and receptive field properties during this critical

period (for review Fox, 2008). In the adult, sensory and most likely also other inputs keep governing the microcircuit on a fine scale. Map plasticity after sensory deprivation (for review see Feldman and Brecht, 2005), and during learning (e.g. Galvez et al., 2006) have been studied extensively and lead to functional readjustments of the microcircuits throughout life.

## 2.2. Ascending pathway and cortical map

The sensory signal flow towards the barrel column starts in the primary afferent fibers that innervate the whisker follicle using a variety of specialized end organs, including Merkel cells, lanceolate- and club-shaped endings, and free nerve endings (Ebara et al., 2002). These diverse innervation types fall into just two functional classes, the slowly and the rapidly adapting afferents (SA and RA) (Gibson and Welker, 1983). The primary sensory neurons with somata in the trigeminal ganglion (TG) carry strictly mono-whisker signals to the brainstem trigeminal nuclei (TN), which consist of the principal nucleus (PrV) and three spinal nuclei (oralis, SpVo; interpolaris, SpVi and caudalis, SpVc) (Fig. 3). These nuclei are subdivided in histologically defined zones, termed 'barrelettes', with each barrelette dedicated to represent predominantly one whisker and together forming a complete map of the whiskers (Ma and Woolsey, 1984; Henderson and Jacquin, 1995). Yet, the TN is the first station on the ascending pathway which integrates information from multiple whiskers. There are cells that respond just to one whisker (mono-whisker cells) (Henderson and Jacquin, 1995; Lo et al., 1999) and others that integrate across whiskers (multi-whisker cells) (Jacquin and Rhoades, 1990; Veinante and Deschênes, 1999; Veinante et al., 2000a; Minnery and Simons, 2003). The interconnection between the four nuclei of the TN is rich and diverse (Jacquin

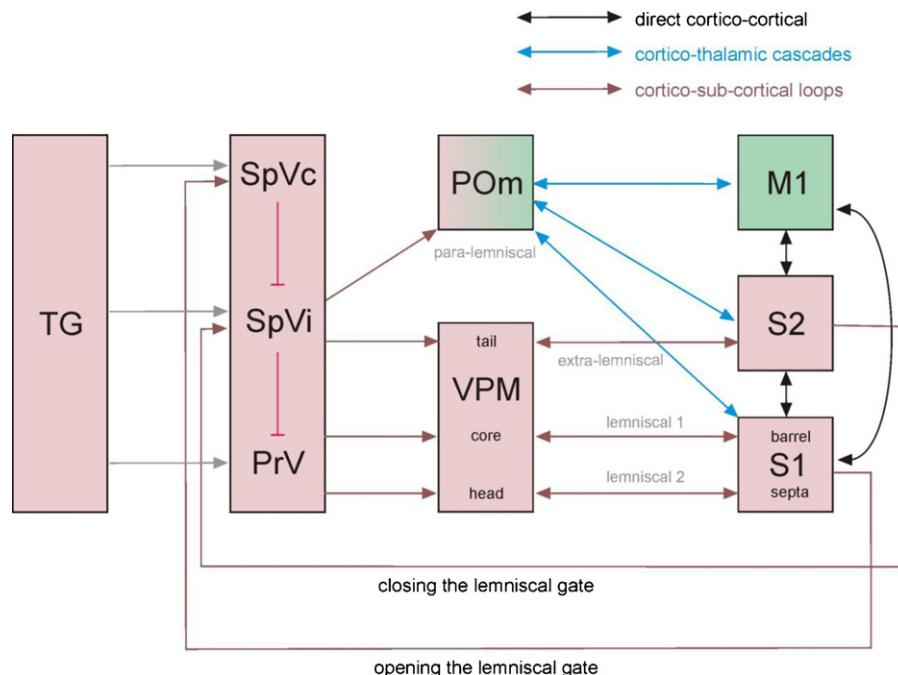

**Fig. 3.** Schematic demonstrating the ascending pathways in the rodent whisker-related sensorimotor system, as well as possible connections associating the sensorimotor cortical signals. The ascending pathway starts with the primary afferents in the trigeminal ganglion (TG) transducing whisker vibrations into neuronal signals and projecting to the trigeminal brainstem complex (TN). The TN consist in the principal nucleus (PrV), and the spinal sub-nuclei (interpolaris SpVi; caudalis SpVc; the detailed connectivity of the oralis sub-nucleus is unknown and is omitted in the figure). The SpVi falls into a caudal and rostral part (SpVic and SpVir). The classical mono-whisker lemniscal pathway (lemniscal 1) originates in PrV barrelettes, and projects via VPM barreloid cores to primary somatosensory cortex (S1) barrel columns. A second lemniscal pathway originating from PrV has been recently discovered which carries multi-whisker signals via barreloid heads to septa (and dysgranular zone) of S1. The extra-lemniscal pathway originates in SpVic and carries multi-whisker signals via barreloid tails in VPM to the secondary somatosensory area. Finally the palelemniscal pathway originates in SpVir and carries multi-whisker signals via POm to S1, S2, and primary motor area (M1). The different colors of connections indicate three principal pathways through which associative coupling between the sensorimotor cortical areas may be realized. Black: direct cortico-cortical connections. Blue: cortico-thalamic cascades. Brown: cortico-sub-cortical loops. Projections of S1 and S2 may open or close the lemniscal gate (i.e. gate signal flow through PrV) by modulating intrinsic TN circuitry.

et al., 1990), with GABAergic projections amongst them (Furuta et al., 2008). Furthermore, feedback projections from higher stations on the ascending pathway, i.e. the primary, secondary somatosensory (S1, S2), and indirectly also the primary motor cortex (M1) exist (Fig. 3) (Furuta et al., 2010). Despite the fact that the knowledge about TN connectivity (intrinsic and extrinsic) is still incomplete, it is clear that important tactile processing takes place at the level of the TN, e.g. integration of signals across whiskers by cells straddling the barrelettes, as mentioned already, computation of direction selectivity, and response adaptation (Minnery and Simons, 2003). The TN divides the ascending pathway into (at least) four separate pathways, two 'lemniscal' ones, an 'extralemniscal' one and a 'paralemniscal' one. These pathways originate from different TN nuclei, and pass through dedicated zones in whisker-related, primary somatosensory thalamic nucleus, the ventro-posterior-medial nucleus (VPM) and higher order medial part of the posterior nuclei (POM) (Chmielowska et al., 1989). POM does not contain histological compartments associated with individual whiskers, but VPM does. It contains the so-called 'barreloids' subdivided into a 'head', 'core', and 'tail' region relaying the different ascending pathways (Urbain and Deschênes, 2007; Furuta et al., 2009a). Further, the four pathways terminate in specific ways in different cortical areas (amongst them S1, S2, and M1) and different columnar systems of the barrel cortex, the barrel columns, septal columns, and the dysgranular zone. The whisker-related barrel column is a cylindrical structure spanning vertically the six layers of barrel cortex although its border is defined exclusively by spatially aligned sub-cellular structures in L4 (mainly L4 dendrites and VPM afferents). Barrels receive their ascending input predominantly from one whisker, the so-called principal whisker (Welker, 1976; Simons, 1978). Septal columns refer to vertically aligned neurons above and below the septa in layer 4; they surround the barrels and separate them from each other (Alloway, 2008). Thus, the barrel columns compare to round islands ordered in rows and arcs (mirroring the spatial arrangement of the whiskers at the snout) surrounded by a sea of septal columns. S1 dysgranular zone is a continuous zone (no barrels, similar to the septal columns) located all around the barrel field but predominantly between the barrel field and the paw representations. The first lemniscal system departs from mono-whisker neurons in PrV, and is relayed via the barreloid cores in VPM to L4, basal L3, L5B, and 6A of the barrel columns (Henderson and Jacquin, 1995; Lo et al., 1999) while the second lemniscal path starts from PrV multi-whisker cells and is relayed via the head of barreloids in VPM to septal columns (Veinante and Deschênes, 1999; Furuta et al., 2009b). The extralemniscal projection originates from multi-whisker cells in rostral SpVi (SpVir), via the barreloid tail and terminates in dysgranular S1 and in S2 (Veinante et al., 2000a; Pierret et al., 2000). Finally the 'paralemniscal' projection starts from multi-whisker cells in the caudal part of SpVi (SpVic) and projects via the anterior POM to barrel cortex L1 and L5a irrespective of barrel and septal columns (Veinante et al., 2000b; Wimmer et al., 2010; Ohno et al., 2011). In contrast, in L4 the POM innervation is specific for septa (Wimmer et al., 2010). Further, POM projects to S2 and M1 and several other sensorimotor or somatosensory associative areas (Deschênes et al., 1998). Most of the knowledge about the microcircuitry originates from work on rat barrel cortex. Mouse barrel columns seem to be organized in similar ways while this species' septal columns appear less prominent and may diverge significantly from the organization known from rats.

### 2.3. Columnar excitatory connections

The mature barrel columnar circuitry serves as a major cortical model system and has been a matter of intense investigation. The most successful tool of connectionist's analysis is still the detailed reconstruction of the entire neuron (Ramon and Cajal, 1921). The

best source of information in the barrel cortex, paired recordings and fillings of synaptically coupled neurons, have yielded a tremendous amount of information about the microcircuitry but also functional properties of neurons (Feldmeyer, 2012). In addition, modern methods of precise and specific stimulation like caged glutamate release and optogenetic approaches have been used (for reviews see Helmstaedter et al., 2007; Petersen, 2007; Schubert et al., 2007; Lübke and Feldmeyer, 2007).

An important question is whether there exists a common blueprint of cortical connectivity and functionality that is similar for all areas across the neocortical sheet. From data obtained in cat visual cortex, Douglas and Martin defined a 'canonical' microcircuit of neocortex implying that most cortical areas have a rather similar basic neuronal network structure (Gilbert and Wiesel, 1983; Gilbert, 1983; Douglas and Martin, 1991, 2004). This concept gives good reason for debate because neocortical areas look alike, but stubbornly, are never exactly the same. For barrel cortex, which compares well to primary visual cortex, another primary sensory area, paired recording and glutamate uncaging studies have indeed revealed that the major excitatory pathways of the canonical microcircuitry defined by Douglas and Martin are present, as recently reviewed in detail (Feldmeyer, 2012; Ahissar and Staiger, 2010). In particular, the lemniscal pathway originating in brainstem principal nucleus of the trigeminal complex is relayed via VPM thalamus and terminates in L4, as do fibers from LGN in V1. Thalamocortical inputs are met with strongly interconnected L4 circuitry which in terms of synaptic numbers and strengths is affected much more by internal cortical circuitry than the thalamic input. L4 then projects the bulk of its output fibers to L2/3 which in turn send a major pathway down to L5 in very similar ways as V1 (Fig. 4A) (Markram et al., 1997; Reyes et al., 1998; Feldmeyer et al., 1999, 2002, 2006; Petersen and Sakmann, 2000; Lübke et al., 2000, 2003; Schubert et al., 2001, 2003; Silver et al., 2003; Bureau et al., 2006; Lefort et al., 2009; Petreanu et al., 2009). Furthermore, as in V1, a thalamo-cortico-thalamic feedback loop exists in which the two major thalamorecipient layers (L4 and L6A) are interconnected and report the cortical state of activity back to the thalamus (Zhang and Deschênes, 1997; Thomson, 2010; Briggs, 2010) (Fig. 4C). Despite such similarities, it is easy to demonstrate strong differences even between sensory areas. 'Strong' means to say that these are differences that even violate a moderate definition of what is canonical, namely that a pathway in order to qualify as canonical *must* exist in every cortical column but may vary in strength. One immediately obvious difference is the L4 subdivision in primary visual cortex (V1) of primates and its associated microcircuitry which is unparalleled even in V1 of other species. In the barrel column L4 spiny neurons target L5A pyramidal neurons (amongst projections to all other cortical layers; Feldmeyer et al., 2005; Schubert et al., 2006; Lefort et al., 2009), a projection that has not been identified for V1 (Fig. 4B). In addition there are many 'weak' differences (i.e. differences in strength) which may pass a moderate definition of what is canonical but may fail on a more orthodox one which would require similar relative strength of canonical projections. For instance, barrel cortex L5A pyramidal neurons form unusually strong projections to supragranular layers with enhanced input to L2 excitatory neurons which, in septal columns, seem to even dominate the L2/3 inputs (Shepherd and Svoboda, 2005; Bureau et al., 2006; Lefort et al., 2009; Oberlaender et al., 2011a), a feature not known from V1. A reverse tendency exists for the projection from L6 to L4, which is functionally well characterized in V1 (Bolz et al., 1989; Stratford et al., 1996; Tarczy-Hornoch et al., 1999) but has not been characterized in the barrel column (Lefort et al., 2009; but see Zhang and Deschênes, 1997; Kumar and Ohana, 2008; Pichon et al., 2012, who show terminal endings of L6 axons in L4). The matter gets worse when comparing primary sensory to motor areas. A common notion is that motor

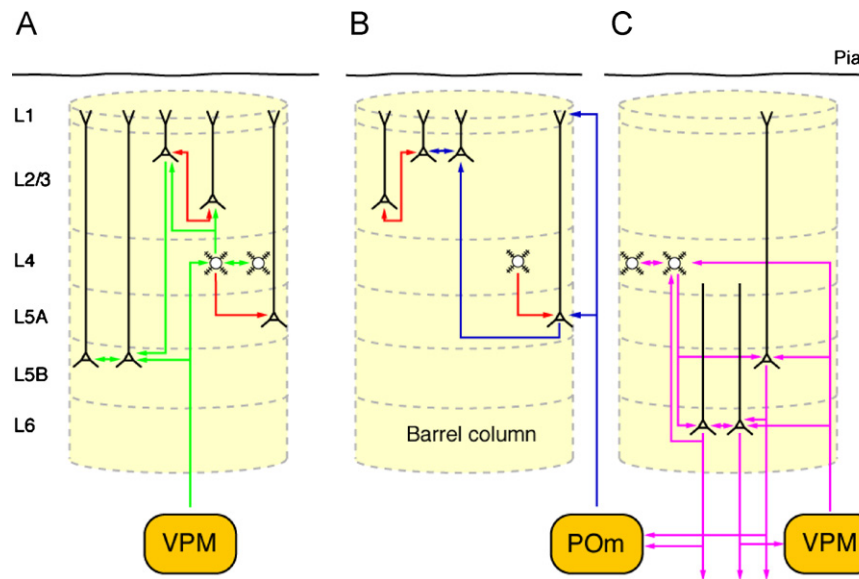

**Fig. 4.** Simplified scheme of parallel neocortical microcircuits in the barrel cortex. (A) The 'canonical' microcircuits receiving lemniscal thalamic input from the ventroposterior medial nucleus (VPM) predominantly in L4 (and to lesser degree in L5B). (B) Intracortical microcircuits involved in the processing from signals arriving from the paralemniscal pathway (input from the posterior medial thalamic nucleus, POm, to L5A pyramidal neurons). (C) Synaptic connections involved in the thalamo-cortico-thalamic feedback circuit between L4 spiny neurons, L5B and L6 pyramidal cells and the thalamic nuclei. L6A pyramidal cell innervate predominantly the sensory specific VPM nucleus, while L5B pyramidal cells form large terminals on neurons in the POm (for review see (Deschênes et al., 1998)). Note that barrel L4 spiny neurons are intrinsic microcircuits. Since synaptic connections involving barrel cortex inhibitory neurons have so far only been characterized in a few studies, they have been omitted for simplicity.

Modified with permission from (Lübke and Feldmeyer, 2007).

cortex virtually lacks L4. Supporting this line of thinking, quantitative mapping and comparison of whisker-related primary and secondary sensory and primary motor cortex using glutamate uncaging led to the proposition that the projection of L2/3 to L5 is the only candidate left to qualify for a canonical projection (Hooks et al., 2011). These conclusions, however, have to be reevaluated in light of the consistent finding from cytometric and molecular analyses that motor cortex does show a small, but functional L4 (Skoglund et al., 1997; Rowell et al., 2010).

In summary, we think to settle the question about a canonical circuit needs further systematic investigations including the painstaking mapping of columnar projections in a large number of neocortical sites/areas. Based on today's knowledge, the result may well be that a canonical circuit according to the moderate and orthodox definition, mentioned above, does not exist, or consists only of one projection. Pondering this outlook, one cannot avoid the impression that the canonical circuit debate may result in pushing functionally important projections, for instance the one from L4 to L2/3, prominent in sensory cortices, into the abyss of non-canonicity, and thus, is in danger to miss the point. How can we better capture the diverse but clearly limited set of combinations known to make up neocortical circuitry? Perhaps a better way is to relax the definition of canonicity even a bit further and drop the requirement that a canonical projection must be found in every cortical column. Stepping short of calling neocortical connectivity *random* (which clearly it is not), the canonical circuit definition in its 'weak' form would define a matrix of canonical connections and associated connection strengths and simply assign the probability with which they occur in neocortex. Obviously, inhibitory circuits that are being unraveled in detail only nowadays, have to be included in the picture. A series of early investigations on fast-spiking inhibitory neurons in rabbit V1, S1 and M1 – identified by the waveform of their spike, the firing patterns and projection targets – clearly point to the notion that the essence of inhibitory circuits making up neocortical circuitry

are likely to be captured by a similar strategy (Swadlow, 1988, 1989, 1990, 1991, 1994).

#### 2.4. Columnar inhibitory connections

The literature on neocortical GABAergic neurons is vast and many efforts have been made to describe their features and to characterize their synaptic connections (e.g. Ascoli et al., 2008). When considering developmental, molecular, electrophysiological and morphological properties in conjunction, many studies on neocortical inhibitory neurons came up with at least 5 main types of inhibitory neurons (Kawaguchi and Kubota, 1997; Gelman and Marin, 2010), although subdivisions have been reported frequently. These inhibitory neuron types are (i) chandelier cells (targeting exclusively axon initial segments), (ii) basket cells (believed to target largely somata and proximal dendrites), (iii) Martinotti cells (targeting distal dendrites, often in L1), (iv) neurogliaform cells (largely thought to signal using volume transmission, Olah et al., 2009) and (v) bipolar/bitufted cells (often targeting dendritic shafts and spines). This subcellular target structure specificity of the inhibitory neurons' axon is the hallmark of many classifications and has been suggested to be independent of the laminar location of the cell body within a cortical column (Markram et al., 2004), but this view is far from unequivocal. Nevertheless, along these lines, several different types of inhibitory neurons have also been identified in the rodent barrel cortex (Bayraktar et al., 2000; Porter et al., 2001; Angulo et al., 2003; Staiger et al., 2004; Ma et al., 2006; Sun et al., 2006; David et al., 2007; Tan et al., 2008; Karagiannis et al., 2009; Sun, 2009; Staiger et al., 2009; Helmstaedter et al., 2009a,b,c). A recent alternative classification of inhibitory neurons in layer 2/3 of the barrel cortex is based on the axonal projection pattern of these neurons with respect to cortical layers and barrel-related columns (Helmstaedter et al., 2009c; Helmstaedter and Feldmeyer, 2010; see also Dumitriu et al., 2007 for a similar approach for visual cortex inhibitory neurons). The main types that

were distinguished by this approach are (i) local (i.e. intracolumnar) inhibitors (including chandelier neurons), (ii) lateral (i.e. transcolumar) inhibitors, (iii) translaminal L2/3-to-L4/5 inhibitors, and (iv) translaminal L2/3-to-L1 inhibitors. These different types of inhibitory neurons have been implicated in feedback as well as feed-forward inhibition. Another approach to classify GABAergic interneurons focuses on molecular markers. There is a bewildering thickset of different molecules and their combinations, including oligopeptide co-transmitters, calcium binding proteins, and receptor subunits, suggesting a huge functional variability amongst cortical GABAergic neurons (Markram et al., 2004; Sugino et al., 2006; Ascoli et al., 2008; Taniguchi et al., 2011). An early attempt to capture the majority of cortical GABAergic neurons (Kawaguchi and Kubota, 1997) proposed to divide them into three groups: parvalbumin expressing (PV, a calcium binding protein), somatostatin expressing (SST), and vasoactive intestinal polypeptide expressing (VIP) (both SST and VIP are oligopeptide co-transmitters). These groups are non-overlapping and account for the majority of cortical GABAergic neurons. Recently this scheme

has been improved by superseding the VIP group by those expressing 5HT3aR, an ionotropic serotonin receptor (containing the obligatory subunit 5HT3a). The 5HT3aR positive neurons are highly heterogeneous, but they are non-overlapping with the PV and SST groups and are a superset of the VIP group. Together with the PV and SST neurons, 5HT3aR cells have been reported to capture virtually 100% of cortical GABAergic neurons (Lee et al., 2010; Rudy et al., 2011).

As in excitatory neurons, the best available information about axonal projections stems from paired recordings/fillings of coupled neurons with subsequent morphological reconstruction. The best studied synaptic connections involving inhibitory neurons are the ones between fast-spiking L4 inhibitory neurons and L4 spiny neurons and L2/3 inhibitory neurons (Sun et al., 2006; Helmstaedter et al., 2008, 2009a, 2009b, 2009c). From such data it is possible to hypothesize that, for each major intrinsic excitatory connection, a parallel inhibitory one exists that provides feed-forward inhibition for this particular pathway (see Fig. 5A and B). The best studied case of cortical feedforward inhibition are the

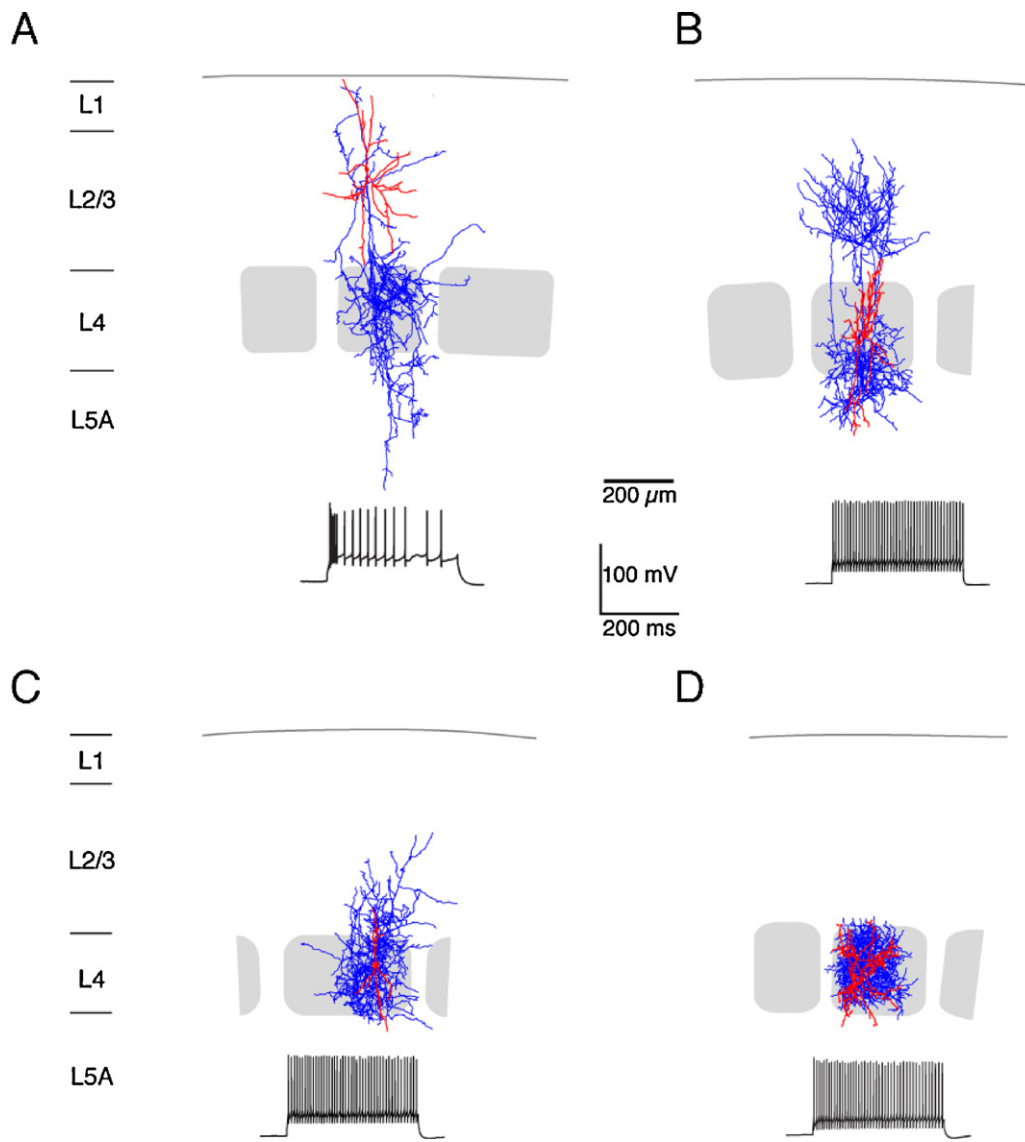

**Fig. 5.** GABAergic interneurons of rat barrel cortex positioned to provide feed forward inhibition for all major trans-laminar projections (L2/3-L5A, L4-L2/3, L4-L2/3 and L5A, VPM-L4, L2/3-L5A). (A) Bipolar, interneuron in L2/3 with axonal clustering in L4 and L5A. (B) L4 FS cell extending its axon in addition to L2/3 and L5A. (C) Same, but with distinct terminal cluster in L2/3. (D) L4 FS cell, known to provide feed-forward inhibition to L4 principal cells. Blue: Axonal arborizations; Red: dendritic tree; gray: L4 barrels; black traces: voltage response of the neuron to an intracellular, rectangular, depolarizing current. Neurons were intracellularly filled with biocytin and reconstructed using NeuroLucida<sup>®</sup> software.



thalamocortical synapses from VPM, which target not only L4 spiny neurons, but also various types of fast spiking inhibitory neurons (Porter et al., 2001; Gabernet et al., 2005; Sun et al., 2006; Cruikshank et al., 2007; Kimura et al., 2010; Staiger et al., 1996) (Fig. 5C and D). The thalamo-recipient inhibitory neurons in turn disynaptically inhibit L4 spiny stellate neurons (Beierlein et al., 2003; Daw et al., 2007). In addition to this disynaptic feed-forward mechanism, trisynaptic feedback inhibition via reciprocal synapse between spiny stellate and inhibitory neurons with a high connectivity ratio exists as well (Kölbl et al., 2010; Cruikshank et al., 2007; Daw et al., 2007). Much less is known about the lemniscal input to non-fast spiking inhibitory neurons or the para-/extralemniscal input to any type of inhibitory neuron and the function of these inputs in intracortical processing (Beierlein et al., 2003; Tan et al., 2008). Together these strong inhibitory effects in L4 are thought to set a short window for synaptic integration by excitatory L4 cells (Brecht and Sakmann, 2002a; Pinto et al., 2003; Bruno and Sakmann, 2006; Wang et al., 2010). Feed-forward inhibition also seems to be implemented in the projection of L4 to L2/3, as tactile information of L4 microcircuits is not only transferred to supragranular pyramidal neurons, but also with high efficacy to several types of L2/3 inhibitory neurons (Helmstaedter et al., 2008; Xu and Callaway, 2009; Xu et al., 2010) (Fig. 5B and C). Further, the supragranular signals are passed on by excitatory pathways mainly to L5 (cf. Kampa et al., 2006). Again a parallel inhibitory projection – albeit not yet characterized by paired recordings – appears to be present: Bipolar-bitufted VIP cells, numerous in L2/3, sample signals from local pyramidal neurons (Porter et al., 1998; Reyes et al., 1998; Rozov et al., 2001) and target L5 pyramidal cells with their rich columnar axons (Bayraktar et al., 2000) (Fig. 5A). Thus, the three most prominent intrinsic projections in sensory cortices are controlled by parallel feedforward inhibitory pathways.

More work is needed to elucidate the contribution of these trans-laminar double track pathways to the balance of excitation and inhibition and to the restriction of signal flow to narrow time windows.

Surprisingly little is known about local infragranular circuits in barrel cortex involving inhibitory neurons, with two notable exceptions. The first is the disynaptic inhibition of pyramidal cells by intervening Martinotti cells (Silberberg and Markram, 2007; Berger et al., 2009; Murayama et al., 2009), the second is the preferential innervation of L6 inhibitory neurons by cortico-thalamic pyramidal cells (West et al., 2006; see also Kumar and Ohana, 2008).

### 2.5. Columnar network dynamics and receptive field properties

Extracellular recordings of action potential firing and intracellular recordings of membrane potential have provided rich information about barrel cortex function. Extracellular microelectrode recordings in anesthetized, awake and behaving rats revealed the typical cortical response in the main receiving column ('the principal column') to precise single-whisker deflections, which is a short lasting excitatory response typically followed by strong inhibition. The inhibitory period suppresses tactile inputs following at a short interval fitting the notion of a fine balance between excitatory and inhibitory signal flows (Simons, 1978, 1985; Carvell and Simons, 1988; Simons et al., 1992; Webber and Stanley, 2004; Stüttgen and Schwarz, 2008; Crochet et al., 2011). Accordingly, frequency adaptation (i.e. response reduction with repetitive whisker stimulation) is commonly observed in the cortex (Simons, 1978, 1985; Garabedian et al., 2003; Arabzadeh et al., 2003; Hartings et al., 2003; Webber and Stanley, 2004; Khatri et al., 2004; Stüttgen and Schwarz, 2010; Sanchez-Jimenez et al., 2009). As expected it is shaped by intracortical inhibition (Moore

and Nelson, 1998; Butovas et al., 2006), but there is also considerable evidence that short term dynamics of thalamocortical (and possibly also intracortical) synapses play a role (Castro-Alamancos and Oldford, 2002; Chung et al., 2002).

Activation of barrel cortex follows a laminar pattern (Armstrong-James et al., 1992; Welker et al., 1993; Celikel et al., 2004). However, relating response patterns to the neuron type by juxtacellular recordings and subsequent neuronal reconstruction (de Kock et al., 2007; de Kock and Sakmann, 2008) confirmed layer-specific delays of transient responses but showed clear deviation from what would be expected from the known anatomically defined sequence of intracolumnar projections discussed before. The shortest latencies were found in L4, and L6, the thalamus-recipient layers, as expected by available anatomical data. However, L5B thick tufted cells, which in the connectionist's scheme rather appear as an endpoint of cortical processing, show similar short latency responses. It is likely that L5 neurons get significant thalamic input via their apical dendrites in L4 or their basal dendrites in L5 and L6 and therefore bypass processing in L4 and L2/3 (White, 1978; Petreanu et al., 2009; Meyer et al., 2010; Oberlaender et al., 2012).

The best-studied properties of barrel cortex receptive fields are multi-whisker integration and directionality. It is important to point out that these properties already exist on the ascending pathway but are transformed at the entry to the barrel cortex (Simons and Carvell, 1989). Therefore, it is an ongoing experimental effort to find out which aspect of the multi-whisker response is due to integration on the ascending pathway and which one is generated by trans-columnar processing (Armstrong-James et al., 1991; Goldreich et al., 1999; Brecht and Sakmann, 2002a; Fox et al., 2003; Kwegyir-Afful et al., 2005; Katz et al., 2006; Wright and Fox, 2010). A current consensus is that trans-columnar processing plays generally a leading role in shaping excitatory and inhibitory parts of receptive fields (Moore and Nelson, 1998; Brecht and Sakmann, 2002a). Importantly, clear differences between barrel and septal columns have been found in the rat. Matching the recent description of ascending pathways which selectively originate from either mono-whisker (lemniscal 1) or multi-whisker TN cells (lemniscal 2, but also extra- and palelemniscal), and terminate in barrel vs. septal columns respectively, it has been consistently found by pharmacological approaches and intracellular recordings that barrel columns receive mono-whisker signals and multi-whisker responses are generated by trans-columnar processes. In contrast, septal columns clearly receive multi-whisker signals which are substantiated by trans-columnar processing (Fox et al., 2003; Wright and Fox, 2010; Brecht and Sakmann, 2002a,b). We will discuss these experiments further in a later section about trans-columnar processing.

Two-photon calcium imaging in L2/3 of barrel cortex in vivo (Helmchen and Denk, 2005; Wallace et al., 2008; Grewe and Helmchen, 2009) has provided additional insights into the spatio-temporal aspects of population responses. Consistent with electrophysiological studies, action potential activity in the superficial layers was found to be low, the response probability relatively small ( $p < 0.4$ ), and trial-to-trial variability high. Single whisker stimulation caused the largest number of spikes in the neuronal population of the principal barrel column, but in addition elicited clear calcium transients in the adjacent columns (Sato et al., 2007; Kerr et al., 2007) (Fig. 6). The work of Kerr et al. showed that population firing cannot be explained by a model assuming independent firing. Accordingly they found pairwise correlations between pairs of neurons that decreased with larger inter-neuron distance. Most interestingly, correlations showed a gradient within a barrel column, with highest correlations between pairs in the center of the principal barrel column and lower ones close to the bordering septal columns. However, individual neighboring

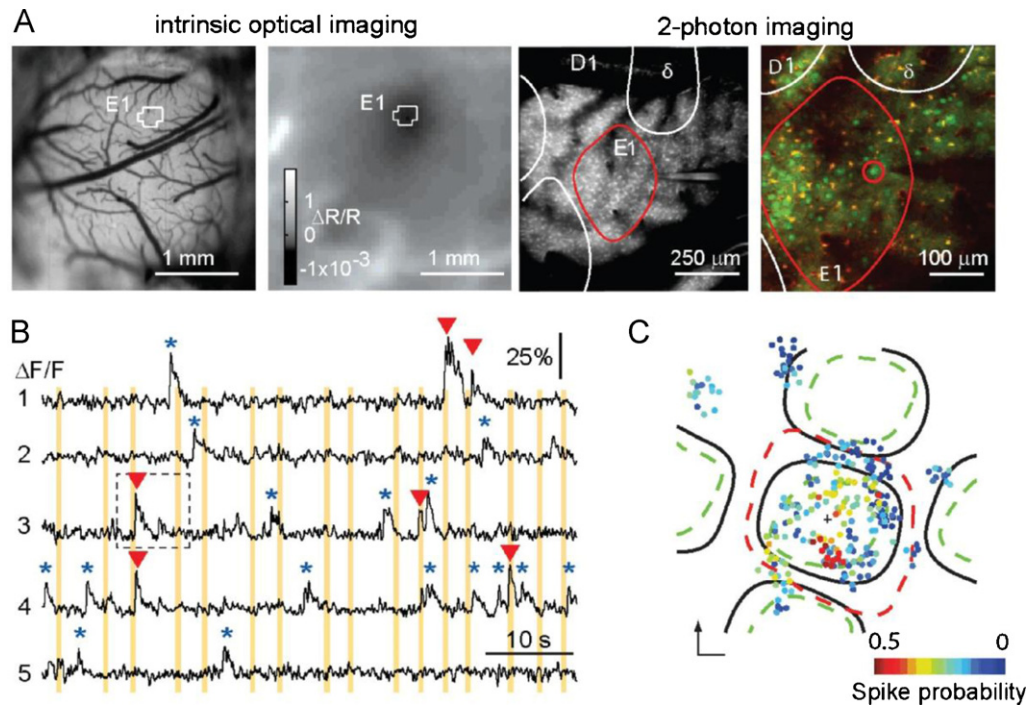

**Fig. 6.** Spatio-temporal aspects of receptive field properties on the population level using 2 photon calcium imaging. (A) In vivo two-photon calcium imaging of neuronal population activity in an identified barrel column. The location of a barrel column (here for the E1 whisker) was identified by analyzing the whisker-evoked reflectance change  $\Delta R/R$  using intrinsic optical imaging (left). Bolus loading of the calcium indicator Oregon Green BAPTA-1 through a glass pipette was targeted to the E1 location resulting in wide-spread green labeling of the neuronal population in L2/3 (right). Astrocytes were additionally stained using the red fluorescent dye sulforhodamine 101. (B) Calcium transients evoked in L2/3 neurons by single-whisker deflections (yellow bars). Note spontaneous calcium transients (blue asterisks) in addition to the stimulus evoked transients (red arrow heads). (C) Spatial map of response probability following whisker deflection as revealed by calcium imaging from L2/3 neuronal populations and overlaid for all experiments after alignment to the principal barrel centers. Minimum (green dashed line), maximum (red dashed line), and average (black lines) barrel column borders are shown. Arcs run vertically, rows run horizontally, and black cross indicates barrel column center. Adapted with permission from Kerr et al. (2007).

neurons could also show highly heterogeneous responses (Sato et al., 2007). These findings are on the one hand consistent with the coarse functional maps observed previously; on the other hand they reveal significant heterogeneity of the spatial and temporal neural response patterns on the fine scale. Further studies are required to understand this heterogeneity, which could in part arise from the various neuronal cell types, but may also indicate the existence of specific sub-networks intermingled in the barrel cortex, e.g. those reflecting specific projections to other cortical areas (Sato and Svoboda, 2010; see also results on heterogeneity in M1 by Huber et al., 2012).

Another interesting question has been whether a particular spatial layout of direction tuning exists in barrel column networks. While a sub-columnar map of vibrissa motion direction was proposed to exist in L2/3 based on extracellular recordings (Andermann and Moore, 2006), no clear relationship between anatomical position and direction selectivity was found in a two-photon imaging study (Kerr et al., 2007). A recent two-photon imaging study reconciled these results by finding a pin-wheel like direction map in adult but not juvenile rats, interestingly suggesting a late emergence of such a map during adulthood (Kremer et al., 2011).

The behavioral relevance of network dynamics and receptive field properties of barrel column neurons is far from being understood. It has been shown that texture discrimination (Carvell and Simons, 1990) as well as object localization (Knutson et al., 2006; O'Connor et al., 2010a,b) can be performed with a single whisker suggesting that multi-whisker integration is not a strong requirement, at least for the so far tested whisker-related functions. The perceptual ability of rodents to discriminate the whisker being stimulated and the direction of a whisker stroke has

not yet been directly investigated. However, high spatial acuity is suggested by learning experiments that allowed rats to use only one single whisker to cross a gap in the dark. Trials needed to relearn the task after changing the whisker was found to be dependent on the distance between the previously used and the new whisker (Harris et al., 1999). Frequency adaptation has been proposed to be modulated by the level of alertness as it has been observed to be reduced during learning, but reappeared prominently after a task has been mastered (Castro-Alamancos, 2004). However, the presence of frequency adaptation is unlikely to be controlled by the level of vigilance and engagement alone, as highly trained animals, which reliably detect near-threshold repetitive stimuli (thus showing a high level of engagement and alertness), do show frequency adaptation in response to these stimuli (Stüttgen and Schwarz, 2010). Accordingly, fitting neuronal sensitivity to the animals' psychophysical performance, suggested that rats use very short read-out intervals in the range of tens of milliseconds to detect the stimuli (Stüttgen and Schwarz, 2010). Such short integration windows are in the time range of the very short touch times during active palpation of surfaces (von Heimendahl et al., 2007).

## 2.6. Perceptual functions of the barrel column

Analysis of perception, one may argue, hardly falls into the range of the microscopic, column-centered views discussed in this section, as performance on a psychophysical task likely involves higher cortical areas and requires cortico-cortical interactions to reach a decision and initialize a motor response. While this interjection is clearly justified, it is also true for the majority of perceptual studies in the whisker system performed so far, that

associations of the barrel column with other cortical processes (despite their undeniable existence) were monitored neither on the physiological nor on the behavioral level. This column-centered (and therefore microscopic) approach is likely reasonable as it has been shown that detection and discrimination of tactile stimuli are blocked by disturbing the integrity of just the barrel column (O'Connor et al., 2010a; Miyashita and Feldman, 2012). Therefore, in this section we will portray perceptual studies that related behavioral measurements to the internal workings of the barrel column and not its interplay with other cortical systems.

The first glimpse into whisker related perceptual capabilities was provided by an elegant study conducted by Hutson and Masterton (1986). Using a Pavlovian conditioned suppression paradigm, it was the first study to provide psychophysical assessment of frequency detection and discrimination. The frequency range tested and the control of the sensory stimuli were limited due to the usage of air-puffs as stimuli (up to 32 Hz for detection and up to 7 Hz for discrimination). Furthermore, the whisker tips were targeted by the air stream, making it difficult to infer the vibrations of the whisker at the shaft, the location that directly stimulates the follicle because biomechanical transformation of tip deflection to shaft vibration is potentially complex (Neimark et al., 2003; Hartmann et al., 2003). Two further groups developed early on a paradigm that is based on instrumental learning to test the whisker-related percept (Guic-Robles et al., 1989; Carvell and Simons, 1990; Guic-Robles et al., 1992). The rats sampled textures across two gaps and chose to jump across one of them to indicate their decision. Rats readily discriminated two textures that deviated in roughness showing the feasibility to use this paradigm to test the rats' perceptual capabilities. However, none of the two studies reported psychometric curves, nor did they attempt to record neuronal activity during discriminative behavior. Using videography, Carvell and Simons (1990) offered a detailed analysis of whisker movements and reported the notable ability of rats to discriminate a smooth surface from a textured one, which featured a grid of microscopic groves 30  $\mu\text{m}$  deep at 90  $\mu\text{m}$  distance. Ever since this result has amazed researchers in the field as this performance was considered to be close to the sensitivity of the human fingertip. The first study that directly compared perceptual correlates with barrel column spike trains was performed more than a decade later using a variant of the task that employed a decision to drink from one of two wells instead of gap crossing as indicator response (von Heimendahl et al., 2007). These authors found that the animals use very short touch times ( $\sim 50$  ms per whisker stroke on average). They also observed that correct discriminations were preceded by increased number of touches and concomitant numbers of spikes. Further behavioral studies focused on conditioned whisker movements across textures and found that so-called stick-and-slip events are generated depending on the roughness of textures, and thus, could contribute significantly to perception (Wolfe et al., 2008; Jadhav et al., 2009a).

The highest precision in comparing neurometric with psychometric data was reached using psychophysical performance in head-fixed rats conditioned to perform a passive detection of whisker deflections (Stüttgen et al., 2006) (Fig. 7A–C). In this study ramp deflections of different amplitudes and maximal velocities were presented to the shaft of one whisker. Applying a Go/NoGo detection paradigm in which animals indicated the detection by licking for a water reward, the perceptual range to detect ramps at different amplitudes and maximal velocities was found to be subdivided into two sections that precisely matched the sensitivity profiles of the two classic types of primary afferents SA and RA. In a further study, the perceptual measurements in the SA-supported channel were conducted simultaneously with barrel cortex unit recordings in the behaving animals (Stüttgen and Schwarz, 2008).

Using probabilistic modeling this study showed that given statistical independence, an ideal observer looking at the 5 most sensitive neurons of the barrel column and receiving from them on average less than one spike per stimulus presentation, is able to detect the presence of a stimulus with the same accuracy as the rat.

Another way to probe perceptual consequences of the barrel column network is the manipulation of its activity. Clearly rats can detect single electrical microstimulation pulses at very low intensity (Butovas and Schwarz, 2007). Houweling and Brecht (2008) went one step further to test the minimum amount of spikes in a barrel related column that creates a percept (Fig. 7D–F). In their experiments, head-fixed rats reported juxtacellular electrical stimulation of single neurons in the barrel column. They found that a burst of 10 spikes introduced into a single barrel cortex neuron are just detectable by the animal. These results together with the psychophysical experiments of Stüttgen and Schwarz (2008) point to the possibility that less than 10 spikes of the  $\sim 4000$  spikes generated in a single barrel column in response to a whisker deflection (de Kock et al., 2007), are sufficient to cause a percept.

Using a frequency discrimination task in head-fixed rats, Gerdjikov et al. (2010) found that rats discriminate pulsatile stimulus frequencies between 60 and 90 Hz by integrating the vibrotactile signals rather than using frequency and kinematic cues (i.e. the pulse waveform). More recent work, however, suggested that stimulus integration is required in the task used by Gerdjikov et al. only because its Go/NoGo structure heavily involve mnemonic functions (Waiblinger et al., 2011). These authors used a detection of change (DOC) paradigm, in which an unrewarded background stimulus (S $^-$ ) and a reward predicting stimulus (S $^+$ ) are presented in seamless sequence. Therefore, the detection of S $^+$  did not require the storage of stimulus information in memory. Contrary to what has been found in the earlier study requiring mnemonic activity, the rats perform much better in the DOC paradigm if kinematic cues (i.e. changes in pulse waveform) are present in the discriminanda. Whenever kinematic cues are lacking, and thus, integration across stimulus pulses is required to do the task, the performance drops significantly. Neurons in barrel cortex reflect this perceptual effect by generating informative spikes only during the first few stimulus pulses after the switch from background to stimulus.

## 2.7. Conclusions: Microscopic view

The classical column-centered approach has revealed important aspects of columnar development, circuitry and function, up to the generation of behavior. Columnar circuitry is complex to say the least. Isolated layer-to-layer projections combined into a scheme of 'canonical' microcircuitry have to be interpreted cautiously in the absence of a full connectionist cortical model (Markram, 2006; Helmstaedter et al., 2007), as columnar dynamics have been shown to deviate from the sequence expected from the microcircuit known so far. The work being done begins to unravel that the column plays a major role in perception of simple whisker stimuli, but the associative nature of this cognitive process has not been tackled in detail. In the next section we will cover advances toward exactly this aim – to combine (i) the observation of columnar activity, (ii) its association with other cortical columns, and (iii) relevant behavior. To do so modern methods of specific monitoring and manipulation of columnar circuitry are combined with precise behavioral measurement of the vibrissa related percept and/or relevant behavioral contexts. Amongst the most promising cellular tools are intracellular and juxtacellular recording/stimulation in vivo (Houweling et al., 2010; de Kock and Sakmann, 2008) which allows functional assessment together with complete morphological reconstruction of the neuron. Particular

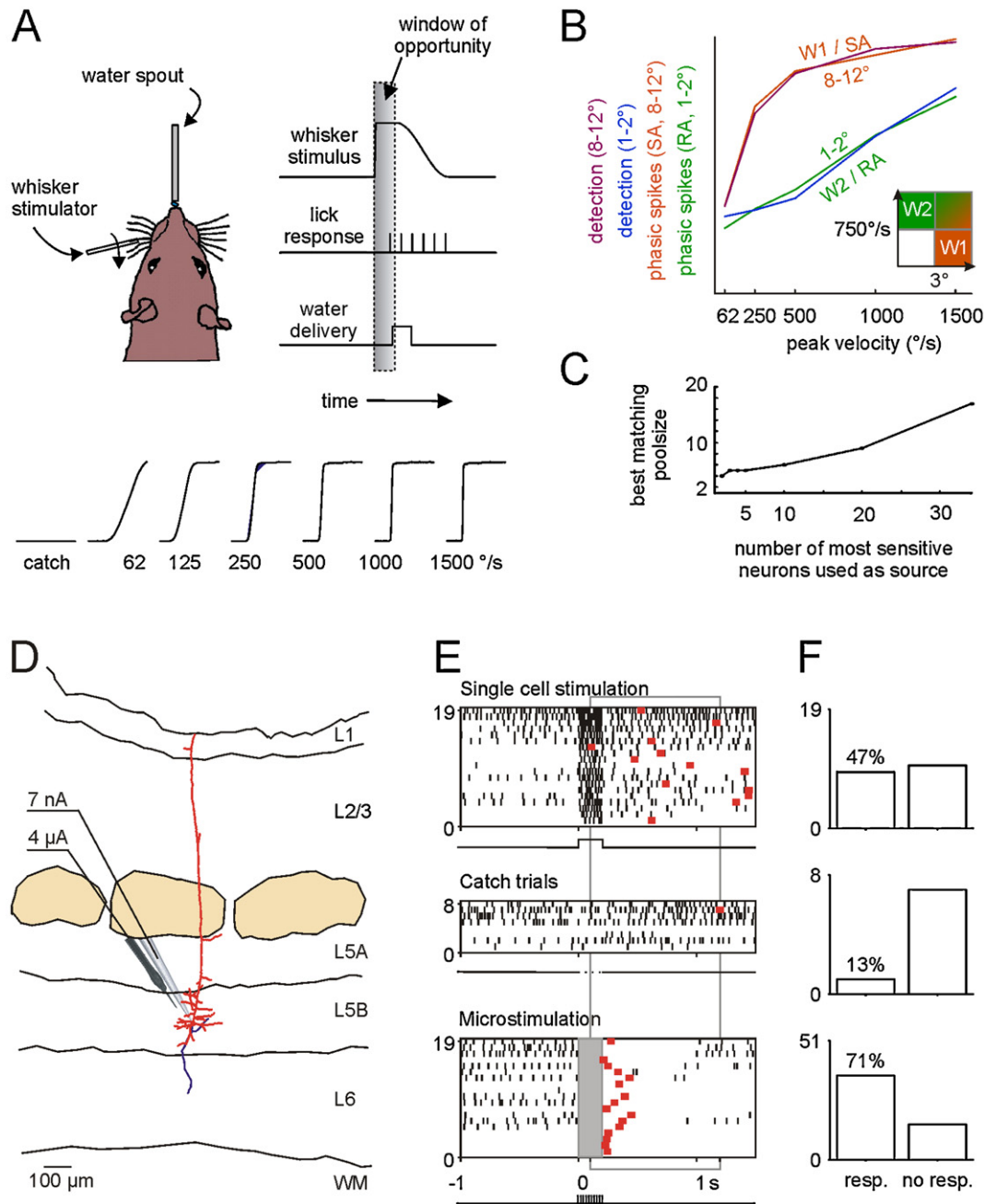

**Fig. 7.** Detection of tactile stimuli and sparse coding in the barrel cortex. (A) Set-up to measure psychophysical detection of a whisker deflection. A behaviorally trained head-fixed rat receives a tactile ramp-and-hold stimulus (bottom, only large amplitude stimuli are shown) to one of its whiskers via a piezo-actuator ('whisker stimulator'). It generates a lick at a water spout to indicate a perceived whisker deflection. If this response is given within a 600 ms window of opportunity that starts with the stimulus onset, the rat is rewarded with a drop of water. (B) Two psychophysical channels for tactile whisker-related perception in rats. Psychometric (obtained by the procedure shown in A) and neurometric curves (phasic spike counts) of the two classes of primary afferents (slowly adapting, SA, and rapidly adapting, RA) are superimposed for small (blue/green) and large amplitude stimuli (red, orange). Choosing appropriate scales for the spike counts and the rat behavior, the two curves can be brought in close correspondence with the respective psychometric curve obtained with the same stimuli. The two psychophysical channels cover different perceptual ranges (inset). W1 (SA) is exclusively used for high amplitude/slow velocity stimuli. W2 (RA) is selectively active for low amplitude/high velocity stimuli. (C) Probabilistic model based on neurometric responses of single units recorded in the barrel column. The pool size needed to match the psychometric performance of the rat ranges between 4 and 15 neurons depending on the selection of neurons to be read out. (D) Reconstruction of the stimulated L5b neuron. Superimposed is a micrograph of a stimulation pipette and a tungsten microstimulation electrode aligned along the histologically verified electrode track. The slender apical dendritic tree (red) was fully reconstructed, whereas the axon (blue) was incompletely filled. Barrels are colored brown. WM = white matter. (E) AP (black ticks) raster plots and first lick responses (red squares) during juxtacellular single cell stimulation trials (top), no-current-injection catch trials (middle) and 19 randomly selected microstimulation trials (bottom). Note that the neuron was inhibited during and following microstimulation (stimulation current: 4 μA). (F) Quantification of responses to single cell stimulation, catch trials and microstimulation. A and B adapted with permission from Stüttgen et al. (2006), C adapted with permission from Stüttgen and Schwarz (2008) and D–F adapted with permission from Houweling and Brecht (2008).

potential is offered further by in vivo calcium imaging using genetically-encoded calcium indicators (GECIs) such as GCaMP-3 (Tian et al., 2009) or Yellow Cameleon 3.60 (Nagai et al., 2004; Lütcke et al., 2010). Using viral approaches these protein indicators

can be stably expressed in confined neuronal populations over weeks or even months (Margolis et al., 2012; O'Connor et al., 2010b). They thus offer (i) monitoring of large populations of neurons, (ii) determining the function of genetically labeled, or

post hoc histologically identified neurons (Bock et al., 2011; Langer and Helmchen F, 2012), and (iii) is starting to be combined with detailed behavioral observation in trained animals (O'Connor et al., 2010a,b). Furthermore, specific manipulation of genetically identified cells by optogenetic tools has been accomplished (Cardin et al., 2009; Mateo et al., 2011). Driving fast-spiking cells induces gamma rhythm and controls sensory responses. Similar approaches will yield decisive information about the functioning of the barrel column in different behavioral contexts.

### 3. The macroscopic view: Associative context

#### 3.1. Specific vs. general contexts: Associative coupling vs. brain states

While the hypothetic associative function of neocortical circuits is almost commonplace, it is a nagging deficit in our current understanding of cortical function that we do not know which pathways contribute and how they establish the coupling of any two neocortical areas. Here we apply structural criteria to order the different candidate neuronal structures that could achieve this. As criteria we use the projection pathway, transmitters involved and specificity of computation. The first three use glutamatergic/GABAergic interactions and rely on spatially precise connection patterns. They are, thus, assumed to reach high specificity of computation and fall into three projection pathways: (1) direct cortico-cortical, (2) cortico-thalamic, and (3) other cortico-sub-cortical interactions. Sensorimotor integration, perception, and cognitive control of any type are amongst the functions that are ascribed to these structures (Fuster, 2009). A fourth class uses also cortico-sub-cortical connections, but involves neuromodulatory brainstem systems (e.g. ventral tegmental area, raphe nuclei, dorsolateral tegmental nuclei, locus ceruleus) using neuromodulatory transmitters (e.g. dopamine, serotonin, acetylcholine, norepinephrine), acting on a host of different postsynaptic receptors, volume transmission and axonal arborizations that extend throughout the brain. The latter class is therefore assumed to exert its functions in profuse and intricate ways in the targeted brain regions. Their functional significance is seen predominantly in the contribution to more general behavioral functions ('states') like vigilance, arousal, mood, and reinforcement. As a cautionary note, we maintain that current knowledge does not exclude the possibility that the functionality of all four discussed ways that potentially couple cortical sites may overlap considerably. In particular, we do not know in how far local release of neuromodulators can cause a change in 'local state', nor is it clear whether and how cortico-cortical coupling of neocortical areas is able to generate (or trigger) 'general brain states'. However, we think the structural differences of the different systems are well suited to guide our thinking about possibilities of cortical association. We will grossly refer to the general internal dynamics dependent on neuromodulation as 'changes in state', while more specific cortico-cortical interactions are tagged 'associative coupling', although it is clear that on the level of cortical dynamics and even more so on the level of behavior, these two influences will be hard to dissect.

The barrel cortex with its exquisite topographic layout and accessibility in rodents is ideally suited to study functional principles of the three routes of associative coupling (Fig. 3) and brain states. There have been extensive investigations into neuromodulation, which make the study of it feasible in conjunction with analyses of cortical coupling. Barrel cortex offers to study the associative recruitment and coupling of sensorimotor areas due to the explicit sensorimotor nature of whisker-related somatosensation. Rodents deliberately move their whiskers to explore their tactile environment, a behavior called whisking. Whisking is hypothesized to be adaptive, adjusting movement

parameters to optimize perception (Carvell and Simons, 1995). In this event, whisker movements must be carefully monitored to be able to counteract the corruption of the tactile signal by self-motion. Thus, somatosensory and motor signals are expected to interact constantly, a fact that is reflected by a dense interconnection of the two systems on all levels of organization (Ferezou et al., 2007; Diamond et al., 2008; Sato and Svoboda, 2010; Petreanu et al., 2012) (Fig. 3).

A boon for the study of cortical association in the whisker system is the fact that S1 is one of a series of adjacent and tightly interconnected sensorimotor areas many of which show a topographic body representation with prominent face and whisker representations and are connected to each other either by juxtaposing the face or limb areas (Fig. 1). Many of these share input from the same thalamic nuclei, VPM, VPL, and POm. M1 is located fronto-medially from S1, shares input from POm and overlaps the limb S1 representation (Hall and Lindholm, 1974). M1 straddles what has been called the agranular medial and lateral fields (AGL and AGM, Brecht et al., 2004; Neafsey et al., 1986). More frontally, cortex assumes anatomical and functional properties reminiscent to pre-motor and pre-frontal areas in primates (Uylyngs et al., 2003). Lateral to S1, we find the predominantly unimodal S2 (Menzel and Barth, 2005) which is oriented such that the face areas touch each other, followed more laterally by the again inverted body representation of the parietal-ventral area (PV) (Remple et al., 2003; Benison et al., 2007). Both S2 and PV receive signals from POm thalamus, with PV showing multimodal responses and providing a link to the amygdala (Shi and Cassell, 1997; Rodgers et al., 2008) and possibly also to the parahippocampal region and hippocampus (Witter et al., 1986). Further, little explored multimodal parieto-medial (PM) and parieto-lateral (PL) areas are located in the triangle between primary somatosensory, auditory and visual areas (Remple et al., 2003) (Fig. 1).

In this second part of the review we will discuss the morphological underpinnings and functional aspects of the three routes of associative coupling as well as neuromodulation. Possible cortico-cortical pathways aligned to the columnar structure in S1 and interconnecting S1, S2, and M1 will be discussed. We will then cover the network dynamics generated by these networks and outline how combination with advanced behavioral observation may finally help to understand the context dependence of cortical activity on a mechanistic level.

#### 3.2. Long-range connections

##### 3.2.1. Direct cortico-cortical projections

The layout of direct cortico-cortical projections within barrel cortex is highly specific for the tiling in barrel and septal columns (Kim and Ebner, 1999). Kim and Ebner described two fairly separated projection systems, one originating from barrel the other from septal columns. The barrel-related horizontal projection system originates mainly from supra- and infragranular layers and shows relatively short projection range inside S1 (a few axonal projections from L4 neurons to adjacent barrel columns do exist as well; see Staiger et al., 2004; Egger et al., 2008). A main projection target is the neighboring septal domain, but also neighboring barrels predominantly targeting L2/3 and L5 (Adesnik and Scanziani, 2010). Horizontal connections in barrel cortex are highly anisotropic showing a clear preference to run along rows rather than arcs of whiskers (Kim and Ebner, 1999; Petersen et al., 2003a; Bruno et al., 2009). These characteristics are similar to those known from other cortical systems, particularly V1 in cats and monkeys, where the cortico-cortical output of a column projects in a clustered fashion - each cluster being a dense innervation of a circumscribed column (Koralek et al., 1990; Lund et al., 1993; Douglas and Martin, 2004). In the vicinity of the origin

the terminal clusters are dense and decrease in density with columns farther away. The anisotropy of projections as found in barrel cortex is a typical finding in other cortico-cortical projection systems as well. It is most likely dependent on the details of the underlying spatial signal representation. For instance, the back projection from primate higher visual areas V2 and V3, to V1 is anisotropic – respecting for instance the striped representation of visual signals in V2 – while projections within V1 are isotropic (Angelucci et al., 2002).

The termination of barrel columns projections outside the whisker-related barrel field are found in a clustered fashion in rat S2 (Koralek et al., 1990; Zhang and Deschênes, 1998; Kim and Ebner, 1999; Chakrabarti and Alloway, 2006). Terminal fields from septal domains are more wide-spread, and farther from the home column, terminate predominantly in other septal columns. Interestingly, this specificity was observed mostly in supragranular layers while infragranular projections tend to blur the borders between barrel vs. septum territory. Like barrel columns, septal ones target S2. However, septal columns are singled out as

they provide the predominant source of the strong projection to M1 (Fig. 8A–C) (Crandall et al., 1986; Alloway et al., 2004; Chakrabarti et al., 2008). In mice, the connectivity of the relatively smaller septal columns is unknown and may differ from the portrayed scheme obtained from work in the rat. Sparse, reciprocal connections exist with bilateral perirhinal cortex (Chakrabarti and Alloway, 2006; Ferezou et al., 2007; Sato and Svoboda, 2010; Aronoff et al., 2010), the contralateral somatosensory cortex (Petreanu et al., 2007), and contralateral motor cortex and ipsilateral orbitofrontal cortex (Aronoff et al., 2010). Reciprocal corticocortical connectivity is generally observed, suggesting bidirectional flow of information linking these cortical regions.

### 3.2.2. Cortico-thalamic loops

The intermediate level of cortico-thalamic loops connecting S1 to S2 or M1 is prominent as well in the whisker system. In the following discussion we will ignore the fact that each cortical site feeds back to itself by a separated loop constituted by layer 6A pyramids to the thalamic nucleus providing its main input. This

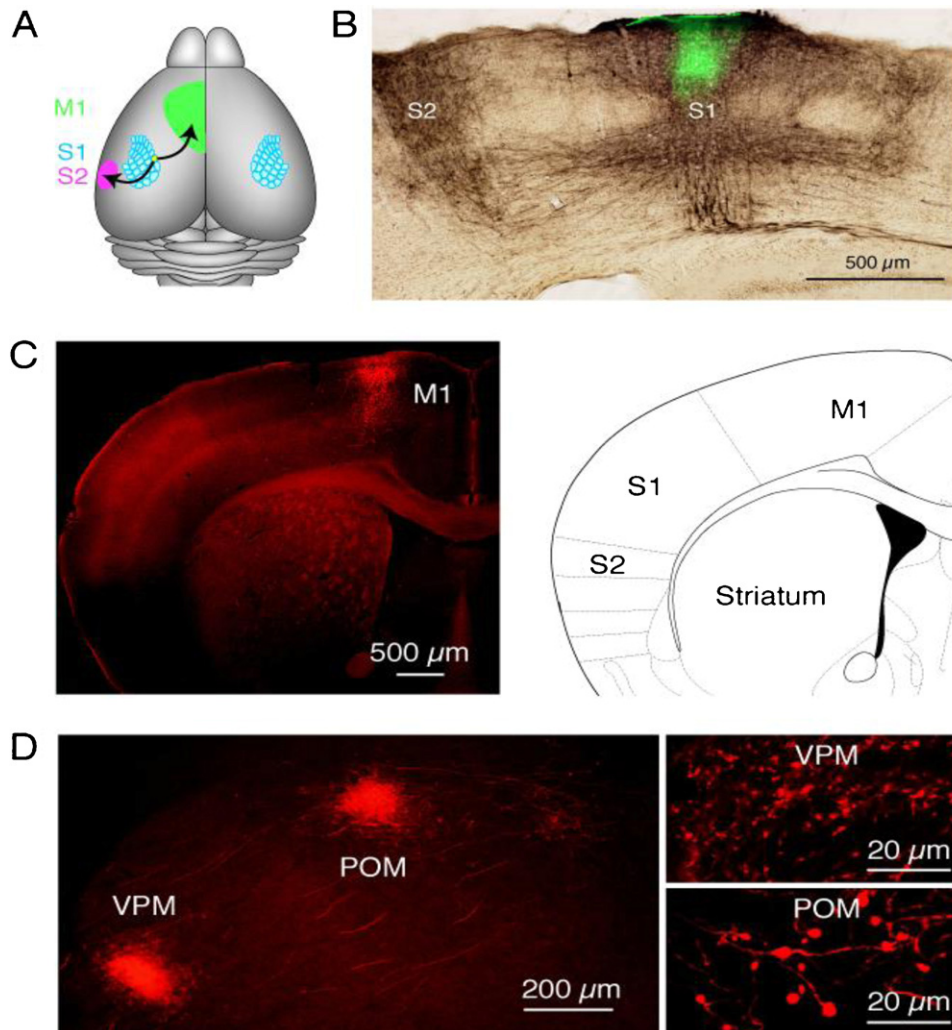

**Fig. 8.** Long-range and local connectivity in rodent barrel cortex. (A) Schematic view of long range output projections from a single column in the barrel field of S1 somatosensory cortex (cyan) to the S2 cortex (violet) and the M1 motor cortex (green). (B) Bright-field image including S1 and S2 region of a mouse neocortex injected with lentivirus encoding green fluorescent protein (GFP) into the C2 barrel column. The original GFP epifluorescence (green central region) from the core of the C2 targeted injection site is overlaid upon the bright-field image stained by anti-GFP immunohistochemistry with nickel-enhanced DAB detection. Axonal projections from the C2 barrel column are evident within the S1 barrel field, medially in the S1 dysgranular zone and laterally as a dense column of innervation in S2. (C) Injection of biotinylated dextran amine (BDA) into the C2 barrel column resulted in prominent labeling of a column of axons projecting to ipsilateral M1. A schematic representation of this coronal section is shown on the right (Paxinos and Franklin, 2001). (D) Fluorescence image of the thalamus from a mouse which had been injected with BDA into the C2 barrel column. The VPM and POM nuclei of the thalamus are strongly labeled. Viewed at higher magnification the boutons in VPM are small (top right) whereas there are both large and small boutons in POM (bottom right).

Adapted with permission from Petersen (2007), B–D with permission from Aronoff et al. (2010).

feedback system is a gatekeeper of its own input but has limited potential to couple far distant neocortical sites (Olsen et al., 2012, but see Zhang and Deschênes, 1997). We will instead focus on barrel cortex L5 neurons sending collaterals to POM (Hoogland et al., 1991; Bourassa et al., 1995; Veinante et al., 2000b; Killackey and Sherman, 2003), a higher thalamic nucleus which connects to several sensorimotor cortical areas (S1, S2, PM, M1, amongst others) (Deschênes et al., 1998; Chmielowska et al., 1989) (Fig. 8D). Cascades of such connections have been described in other cortical areas as well and have been proposed as a general means to couple different neocortical areas (Sherman and Guillery, 2011). The L5 projections to POM terminates in efficacious synapses showing strong short term depression (Groh et al., 2008). In vitro, the disynaptic path via POM has been demonstrated to readily drive S2 activity (Theyel et al., 2010). A gating function of the POM pathway is discussed, based on, firstly, the thalamus relay cell's ability to switch from burst firing to tonic firing and, secondly, on synaptic inhibition from zona incerta ventralis (Zlv), a thalamus associated nucleus receiving inputs from motor cortex and sending inhibitory inputs to POM (Bartho et al., 2002; Bokor et al., 2005; Lavallée et al., 2005). In the quiescent state of the animal, the tactile pathway to S1 and S2 via POM is expected to be in the burst mode and cortico-cortical transmission would be limited to transmitting activity in a highly non-linear way (Sherman and Guillery, 2011). However, during whisking M1 inputs would release inhibition from POM by activating an inhibitory synapse inside Zlv which in turn would reduce inhibitory Zlv output to the POM. During whisking POM could thereby switch to the regular firing mode and reliably transmit signals between S1, S2, and M1 (Trageser et al., 2006; Trageser and Keller, 2004; Urbain and Deschênes, 2007) (Fig. 3).

### 3.2.3. Cortico-subcortical loops

The sub-cortical pathway departs mostly from L5 large pyramids that – beyond thalamus – project as well to brainstem, reticular formation, tectum, the basal ganglia, and the cerebellar networks amongst others (see for review, Bosman et al. (2011); see also Kozloski et al., 2001 for the visual cortex). These targets are all involved somehow in the generation (and/or orchestration) of motor output, i.e. behavior (Guillery and Sherman, 2002). At the same time, however, they send signals back to neocortex, thereby having an unknown effect in coupling of neocortical areas. While all these projection systems are worth to be studied in their own right, we focus here on the strong cortico-fugal projections from sensorimotor areas to TN. As TN is a major relay of afferent tactile signals it closes the loop via the ascending projections to exactly the same sensorimotor areas (S1, S2, M1 amongst others). The cortico-fugal loop, therefore is closed and may serve as a relative simple model system to study the role of cortico-sub-cortical loops in cortical association (Fig. 3). The caudal sector of the SpVi, the SpVic, contains numerous inhibitory neurons that exert inhibitory control on PrV, thus gating the flow of sensory information through this nucleus (Jacquin et al., 1989a,b; Timofeeva et al., 2004). The SpVic is itself under the inhibitory control of the caudalis nucleus of the trigeminal complex (SpVc) which increases sensory traffic through PrV by dis-inhibiting it from the inhibitory drive of the SpVic (Furuta et al., 2010). It is almost certain that many more such interconnections exist in the TN, leaving interesting work for the future. The important insight is that these intricate intrinsic connections may gate or block a subset of the ascending channels and that this gate may be controlled by direct cortico-bulbar connections from S1 and S2, and an indirect one from M1 (Furuta et al., 2010). Interestingly, the projection from S1 to SpVi also appears to be directly involved in controlling whisker movements, since stimulation of S1 neurons when M1 is inactivated, and SpVi stimulation alone drives retraction of the contralateral whisker (Matyas et al., 2010). In conclusion, these cortical-subcortical loops

are candidates to establish associations between the contributing areas in parallel to their direct cortico-cortical counterparts.

### 3.2.4. Neuromodulatory systems

One potent source of setting brain states is the release of neuromodulators from the reticular formation and basal forebrain to sub-cortical and cortical networks. A major role is played by acetylcholine (ACh), norepinephrine (NE), and other neurotransmitters which act in thalamus and cortex amongst other structures (McCormick and Bal, 1997; Buzsaki et al., 1988; Kristt, 1979; Kristt and Waldman, 1981; Houser et al., 1985). ACh modulates barrel cortex activity in complex ways, via pre- and postsynaptic mechanisms involving both nicotinic and muscarinic ACh receptors and highly specific effects on excitatory vs. inhibitory neurons. Together, ACh-related effects may increase signal to noise ratio for behaviorally relevant signals (Gil et al., 1997; Oldford and Castro-Alamancos, 2003; Gullledge and Stuart, 2005; Eggermann and Feldmeyer, 2009; Gullledge and Kawaguchi, 2007; Porter et al., 1999; Christophe et al., 2002). A recent study by Constantinople and Bruno (2011) has also implicated a decisive role for norepinephrine in the control of cortical states. They recorded from neurons in L2 to L6 of the rat barrel cortex under anesthesia and subsequent wakefulness. Both states differed markedly in their temporal pattern of synaptic inputs. During wakefulness, immediately following removal of anesthesia, prolonged periods of synaptic quiescence (DOWN states) were abolished in all layers and all neurons showed persistently depolarized membrane potential reminiscent of cortical UP states. These depolarized states were prevented by antagonists of norepinephrine, but not of ACh or 5-HT. These results in rats comparing slow wave anesthetized and desynchronized awake cortical states (Constantinople and Bruno, 2011) need to be reconciled with findings in mice comparing the slow wave cortical state during quiet wakefulness and the desynchronised active whisking state (Poulet et al., 2012). During quiet wakefulness, when the whiskers are not moving, action potential firing rates are low in the somatosensory thalamus and the cortex exhibits prominent slow membrane potential fluctuations. However, during active whisking, thalamic firing rates increase strongly, driving the neocortex into the active desynchronized state. Interestingly, neither the change in thalamic firing rate nor the cortical state change depends upon sensory information from the periphery. The recruitment of neuromodulatory processes for vigilance related states vs. specific behavioral states needs to be elucidated by future experiments.

### 3.3. Transcolumnar processing

Despite the exquisitely resolved anatomical maps, most cells in the ascending whisker-related system display multi-whisker responses to varying degrees. A bias towards mono-whisker responses is present in some PrV neurons giving rise to the lemniscal 1 pathway. However, extracellular and intracellular measurements revealed that receptive fields of thalamic and cortical neurons of all layers in barrel and septal columns are surprisingly broad (Simons, 1978; Moore and Nelson, 1998; Zhu and Connors, 1999; Brecht and Sakmann, 2002a,b; Brecht et al., 2003; Manns et al., 2004). Broad receptive fields may endow neocortical neurons with important integrative functions beyond trivial sensory representations and allow adaptive sensory processing in response to context dependent needs. Experiments designed to find out in how far multi-whisker convergence is shaped by trans-columnar processing commonly found that receptive field size is determined strongly by trans-columnar processing (Carvell and Simons, 1988; Moore and Nelson, 1998; Schubert et al., 2001, 2003; Brecht et al., 2003; Manns et al., 2004). An exception may be L4, where either strong or absent effects on

the receptive field size after lesion of the neighboring column were found (Armstrong-James et al., 1991; Goldreich et al., 1999). The reason may have been the usage of urethane as anesthesia or differences in the extent of the lesion in the neighboring barrel column. More recent studies inactivated all of barrel cortex with surface application of muscimol, a GABA receptor agonist, and recovered only the column of interest with local application of the competitive antagonist bicuculline, in an attempt to isolate the impact of thalamic inputs on the cortical receptive fields. Receptive fields of L4 neurons (Fox et al., 2003, as well as those in L5: Wright and Fox, 2010) shrink considerably with respect to control under these circumstances, suggesting that a substantial part of the receptive field is generated by trans-columnar processes. Another study found that L4 receptive field changes following manipulation of receptive field size on the level of TN, can be largely explained by this sub-cortical manipulation, and thus, argues against a dominant trans-columnar effect (Kwegyir-Afful et al., 2005). In summary, while the situation in L4 remains not fully resolved, there is otherwise consensus that inhibitory and excitatory subfields are generated by intracortical mechanisms (Carvell and Simons, 1988; Moore and Nelson, 1998; Schubert et al., 2001, 2003; Brecht et al., 2003; Manns et al., 2004). In the thalamus sensory activation elicits excitatory or inhibitory responses which tend to be spatiotemporally segregated, i.e. different whiskers often evoke purely excitatory or inhibitory responses and if whiskers evoke both excitatory and inhibitory responses these response components are segregated in time (Brecht and Sakmann, 2002b). In contrast, in the cortex all whiskers tend to evoke mixed excitatory and inhibitory responses, which overlap in time,

although excitation tends to lead with shortest latencies (Moore and Nelson, 1998; Brecht and Sakmann, 2002a).

Spontaneous activity is clearly transcolumnar as it sweeps through the barrel field in a wave-like fashion, reflecting the occurrence of UP states (versus more quiet DOWN states) as seen in intracellular recordings in anesthetized animals (Petersen et al., 2003b). Studies using large scale voltage sensitive dye (VSD) recordings demonstrated the spatiotemporal progression of evoked sub-threshold tactile activity. Single-whisker deflection leads to an initially confined activation of the respective barrel column followed by a rapid horizontal spread across the entire barrel field within  $\sim 50$  ms (Petersen et al., 2003a) (Fig. 9A and B). Most interestingly, sensory-evoked VSD responses depend on the network state at the moment of whisker stimulation, with more confined activation and less spread during UP states

The spread of activity across large parts of sensorimotor cortex in both hemispheres has been further studied using large craniotomies. Whisker stimulation causes not only an excitation across the whole barrel field, but at a delay, also excites M1 in anesthetized and awake mice (Ferezou et al., 2007) (Fig. 9C). Thus, M1 activation does not happen by the travelling of a contiguous wave across the neocortex, suggesting that it is not evoked via short range interconnections from one column to the next. The wide-spread activity evoked by single whisker stimulation can be blocked by local inhibition of glutamatergic synaptic transmission, suggesting that at least in part it is driven by the activity of excitatory neurons in the barrel cortex. Future studies need to resolve the progression of sensory information within S1 and across neocortical areas at higher resolution and use optogenetic or

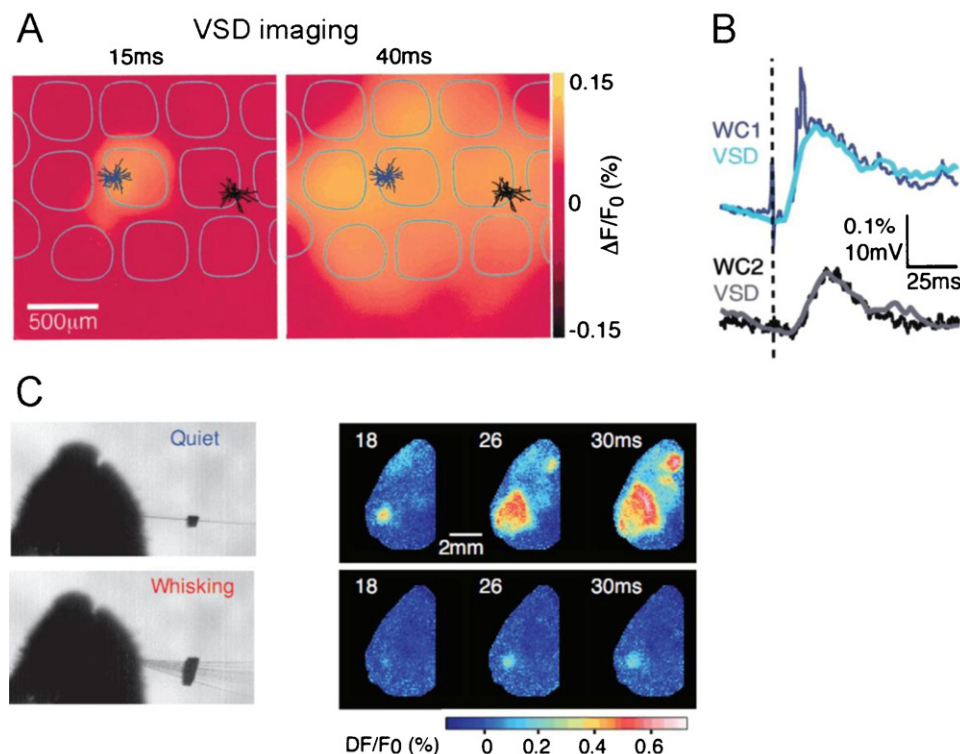

**Fig. 9.** Imaging barrel cortex activation in vivo on a coarse and fine spatial scale. (A) Voltage-sensitive dye (VSD) imaging of the spread of cortical activation following deflection of a single whisker using the dye RH1691. The relative fluorescence change  $\Delta F/F$  is shown for two time points following the stimulation. (B) Comparison of dual whole-cell (WC) recordings from two L2/3 pyramidal neurons and the local VSD signals, demonstrating that VSD signals closely follow the subthreshold membrane potential of the respective neurons. The latency, amplitude, and kinetics of the VSD signal and the membrane potential changes are well matched for both neurons. The early deviation in the WC recording from the blue neuron is caused by action potentials, which in general are not well correlated with a VSD signal. The VSD signal is scaled identically for the two locations, indicating that the VSD image can be calibrated linearly and used to predict the membrane potential changes across the field of view. (C) Voltage sensitive dye imaging from barrel cortex of awake mouse. A downward deflection of a single whisker in the awake mouse reveals a large amplitude, wide-spreading VSD response when the mouse is resting as compared to a spatially restricted, small amplitude response during whisking.

Panels A and B adapted with permission from Petersen et al. (2003a); panel C adapted with permission from Ferezou et al. (2006).



pharmacological manipulation to elucidate which of the three cortico-cortical pathways discussed here is involved in conveying it. In vitro studies clearly show that direct cortico-cortical as well as cortico-thalamic projections may contribute in specific ways (Theyel et al., 2010; Adesnik and Scanziani, 2010). The progression of sensory signals across large areas of neocortex speaks in favor of an integrative nature of cortical processing, in which sensory signals from an individual whisker need to be processed in the context of other sensory inputs (other whiskers, other tactile inputs and also other sensory modalities) and of expectations derived from previous sensory experience, self-generated movements and behavioral goals. In the following we will discuss experiments which have started to experimentally control such contexts.

#### 3.4. Studying associative coupling using whisking behavior

In recent years, researchers have begun to make high-resolution electrophysiological and optical recordings from neocortex in awake rodents during whisking movements in air or against objects (Fanselow and Nicolelis, 1999; Hentschke et al., 2006; Lee et al., 2006; Crochet and Petersen, 2006; Fujisawa et al., 2008; Poulet and Petersen, 2008; Jadhav et al., 2009a; Ferezou et al., 2007; Greenberg et al., 2008; Sawinski et al., 2009). Whole-cell patch-clamp and sharp microelectrode intracellular recordings have revealed intense barrages of synaptic inputs to both excitatory and inhibitory barrel cortex neurons in awake resting mice (Crochet and Petersen, 2006; Poulet and Petersen, 2008; Gentet et al., 2010) and rats (Okun et al., 2010) (Fig. 10A). Typically, large amplitude (10–20 mV) oscillations of the membrane potential are recorded in the 1–5 Hz range when the animal is sitting still and the whiskers are not moving. Extracellular measures of global sub-threshold synaptic activity in barrel cortex of awake mice using local field potential recordings (Poulet and Petersen, 2008) or voltage sensitive dye imaging (Ferezou et al., 2006, 2007) also show slow oscillations highly correlated with membrane potential recordings that form waves of activity propagating across the barrel cortex.

When mice start to move their whiskers, with no objects in the way, the slow oscillations are reduced in amplitude and replaced by faster, lower amplitude synaptic activity (Crochet and Petersen, 2006; Poulet and Petersen, 2008) (Fig. 10A and B). Chronic recordings in infragranular layers while rats performed a whisking task have shown that firing rates are increased during whisking (Hentschke et al., 2006), a statement which has recently been rendered more precisely to be a specific increment of firing rates in L5A (de Kock and Sakmann, 2009). In other layers, however, firing rate does not report the change in sub-threshold activity pattern (Poulet and Petersen, 2008; de Kock and Sakmann, 2009). Furthermore, the horizontal spread of the sensory response has been observed to be decreased (Hentschke et al., 2006; Ferezou et al., 2006) (Fig. 9C) and temporal interaction between repetitive stimuli is reduced (Fanselow and Nicolelis, 1999; Lee et al., 2008). Dual whole-cell recordings and simultaneous whole-cell, local field potential and EEG recordings allowed an analysis of the patterns of correlation during different states in the barrel cortex (Fig. 10A and B). These experiments showed that during the resting state sub-threshold, but not spiking activity, is indeed highly correlated in nearby cortical neurons, but is significantly reduced during the active state (Poulet and Petersen, 2008; Gentet et al., 2010). Coherence analysis showed that the slow oscillations (but reaching up to ~30 Hz) were almost entirely responsible for the high correlation in resting state and decorrelation in the active state (Poulet and Petersen, 2008). In vivo two-photon microscopy has recently been used to target whole-cell recordings to L2/3 inhibitory and excitatory neurons during resting and active states

in mouse barrel cortex (Gentet et al., 2010) (Fig. 10C) Similar to dual excitatory–excitatory neuron recordings, the membrane potential was highly correlated between pairs of excitatory, FS and non-FS inhibitory neurons during quiet wakefulness and the correlations were reduced during active whisking. A recent study worked out that activity of somatostatin containing inhibitory neurons, a class of inhibitory neurons that innervate distal dendrites of excitatory neurons, does not correlate with the membrane potential fluctuations of other types of nearby neurons. These somatostatin neurons are tonically active during quiet wakefulness but hyperpolarize and reduce firing in response to tactile input and during whisking (Gentet et al., 2012), probably opening a Martinotti cell-dependent inhibitory gate to allow dendritic sensory signal processing in cortical L1 (Fig. 10D).

The fact that global EEG recordings capture most of the changes seen on the cellular level in spontaneously whisking mice and that thalamic neurons are involved in the whisking-mediated changes (Poulet and Petersen, 2008; Poulet et al., 2012) are compatible with being caused by a brain state. At present, however, experiments using specific manipulation of neuromodulatory systems during behavior are lacking and the detailed contribution of cortico-thalamic or sub-cortical pathways has to be worked out. In fact, a combined lesion and electrophysiological study in rats, clearly pointed to a critical contribution of the sub-cortical TN in generating the hallmark effect of active touch, i.e. reduction of tactile response during whisking (Lee et al., 2008): Using electrical stimulation at different stations of the ascending tactile pathway, these authors showed that response reduction only occurs when stimulating fibers presynaptic to TN, but is inverted when stimulating the axons leaving the TN. Therefore, they concluded that response reduction in active touch must happen in the brainstem. Lesions in TN pointed to a pivotal role of inhibition of PrV by SpVic (Lee et al., 2008; Furuta et al., 2008). In view of the cortical control of SpVi by S1 and S2 cortices (Furuta et al., 2010), this suggests the contribution of sub-cortical associative mechanisms. More recently, the direct cortico-cortical projection from M1 to S1 has been investigated by combining axonal transport of genetically encoded calcium dye GCaMP3 with two photon calcium imaging of M1 presynaptic terminals in barrel cortex layer 1 (Petreanu et al., 2012). Training mice to detect an object in the vicinity of their face using whisker movements, these authors found that direct cortico-cortical connections are used to inform S1 about motor but also about sensory events (i.e. object contact). The same set of signals were found to be encoded in M1 L2/3 neurons the major site of origin for M1-S1 projection (Mao et al., 2011; Huber et al., 2012), suggesting that M1-S1 communication via direct cortico-cortical fibers is comprehensive and thus may play an important role in sensorimotor integration. The activity of somatostatin-expressing GABAergic neurons described above, might contribute to regulating the input from M1 into S1. The somatostatin-expressing neurons innervate distal dendrites in layer 1, the exact region targeted by the superficial axons from M1. That somatostatin-expressing neurons reduce firing rate during active whisking, might therefore promote the integration of motor input onto S1 pyramidal neurons during active sensing (Gentet et al., 2012).

#### 4. Combining the microscopic and macroscopic view. The need to study relevant sensorimotor or cognitive behavior

The studies discussed in the last section have begun to search for answers to the major questions to be resolved in future studies, which are, firstly, to what extent the observed cellular changes are due to the brain state or associative coupling via the three pathways of cortico-cortical communication, and secondly, what is the role of the columnar microcircuitry in achieving this

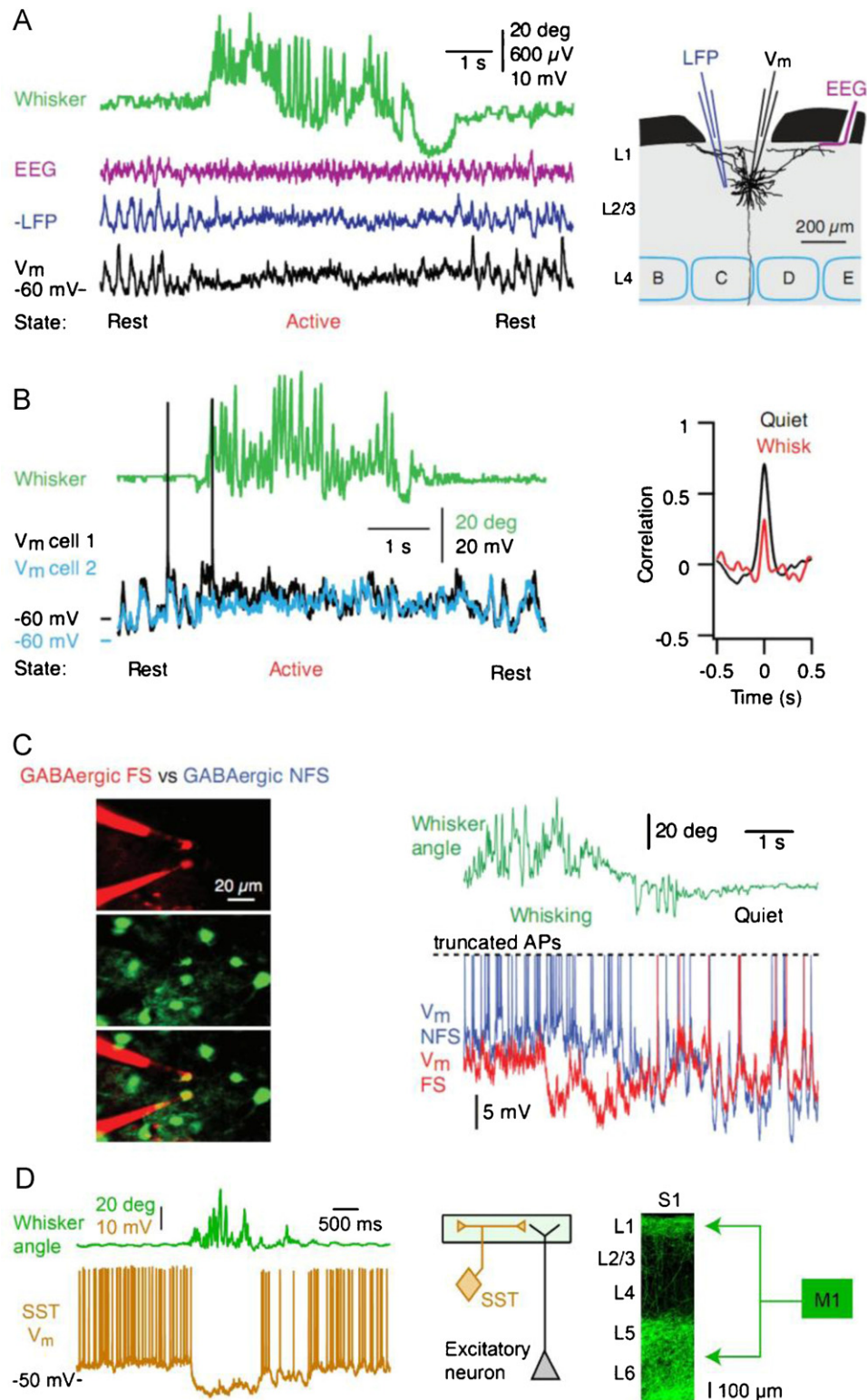

**Fig. 10.** State dependent cortical processing in barrel cortex of behaving mice. (A) Left: Simultaneous whole cell (V<sub>m</sub>, black), electroencephalogram (EEG, purple), local field potential (LFP, blue) and whisker movement (green) recordings show change in cortical state as the mouse starts to whisk; right: anatomy of cell recorded on left and cartoon showing recording configuration. (B) Left: dual whole-cell recordings from L2/3 barrel cortex neurons during rest and whisker movements, right: cross correlation analysis shows a high degree of correlation in membrane potentials during rest and a reduction in correlation during the active state when whiskers are moving. (C) Two-photon targeted dual whole-cell recording from L2/3 GFP labeled GABAergic neurons in the GAD67-GFP knock-in mouse. The fast spiking (FS, red) and the non-fast spiking inhibitory neuron (NFS, blue) show largely correlated membrane potential traces (less so during whisking). (D) Whisker trace and whole-cell recording from an somatostatin expressing GABAergic interneuron (SST, left). Like no other inhibitory cortical cell investigated in detail so far, this neuron shows whisking dependent hyperpolarized and its firing rate suppressed during whisking. As SST cells inhibit distal pyramidal dendrites in L1 (center) they may be able to selectively disinhibit those structures during whisking. Axonal tracings show that M1 inputs are targeted specifically to L1 in barrel cortex (right). Figures adapted with permission from Poulet and Petersen (2008), Gentet et al. (2010, 2012).

coupling. Clearly, the novel optical and intracellular methods to monitor and manipulate cells, dendrites and axons in great detail in vivo will be indispensable for this endeavor. A further decisive development is the use of animals trained to operant behavior with precisely monitored sensory input and motor output, preferably involving perceptual measurements (Schwarz et al., 2010). Operant behavior and stable psychometric performance allow to control brain states due to general variables like vigilance and motivation, and attentional processes can be specifically cued. Furthermore, it assures that the cortical system under investigation is actually being used for the specific sensorimotor integration.

It is clear that brain states and associative coupling via specific pathways will be engaged differently in different behavioral situations. Thus in future work, we will need to decide which aspects of behavior will be the most promising to look at to make progress in the understanding of cortical processing. Specifically, we need to ask what is the experimental condition that engages best the communication between cortical areas? And, how can we differentiate best between effects of neuromodulation and associative coupling? In the following we will argue that we will need a fresh look at the functional aspects of barrel cortex that aims beyond the understanding of sensory processing. The extensive whisker-related behavioral repertoire of rodents suggests that in addition to tactile perception, vibrissae-related neuronal activity plays a role in sensorimotor, mnemonic and cognitive functions, the study of which will have to be incorporated in future research.

To motivate these new directions of research it is helpful to ask how barrel cortex activity relates to the animal's percept. Sensory cortices seem to contribute to perception because they undergo plastic changes during learning of perceptual tasks that reflect specific characteristics of the conditioned stimulus (CS) in space and time (Disterhoft and Stuart, 1976; Kitzes et al., 1978; Diamond and Weinberger, 1986; Diamond and Weinberger, 1989; Recanzone et al., 1992, 1993; Schoups et al., 2001; Ghose et al., 2002). Furthermore, neuronal activity evoked by electrical microstimulation (Butovas and Schwarz, 2007), optogenetic stimulation (Huber et al., 2008) and even juxtacellular stimulation of single neurons (Houweling and Brecht, 2008) in V1 and barrel cortex are perceived by rodents. However, lesion studies demonstrated that the relationship between activity in primary sensory cortices and perception is complex. For instance it has been shown that conditioning of detection and discrimination performance of tactile frequency is possible after a near-complete lesion of the barrel cortex (Hutson and Masterton, 1986). These authors used a classical conditioning paradigm (conditioned suppression) and trained rats on a gap jumping task that required palpation of a gap in a runway in order to cross it. In contrast to the psychophysical tasks, which did not involve active palpation, gap jumping was abolished by barrel cortex lesion. Hutson and Masterton suggested that it is active vs. passive perception that might be the factor that determines the indispensability of barrel cortex. However, this notion was rendered unlikely by recent experiments using operantly conditioned rats that clearly demonstrated the involvement of barrel cortex in a passive detection/discrimination task (Miyashita and Feldman, 2012). A closer look at the behavioral methods used by Hutson and Masterton reveals that in their perceptual studies the unconditioned stimulus (US, reward, electrical shock) was presented simultaneously with the conditioned stimulus CS (sensory stimulus). Thus the conditioning was of the 'delay' type (simultaneous CS and US) rather than of the 'trace' type (CS and US presentation separated in time). A possible interpretation of this commonality is that the successful association of CS and US in these paradigms could have been achieved by their simultaneous occurrence and did not require any involvement of memory functions. The notion thus arises that it

may be the requirement of a memory trace that determines whether cortical structures will be indispensable to learn a given perceptual task. In support of this notion, there is ample evidence indicating that the brain structures critical for classical delay conditioning (cerebellum, brainstem: Clark et al., 1984; Mauk and Thompson, 1987) are different from those necessary for trace conditioning (hippocampus, neocortex, cerebellum: Weiss et al., 2006). Galvez et al. (2007) conducted experiments that directly showed that barrel cortex contribution to acquisition and retention of the classically conditioned eye lid reflex is indeed critical if the CS and US are presented in sequence, separate in time, while in the case CS and US overlapped in time, learning occurred even in the absence of barrel cortex. Long-term mnemonic functions of barrel cortex for whisker-related behavior have been suggested also based on operant conditioning of gap jumping. Harris et al. (1999) first trained single-whisker animals to cross a gap using the whisker and then cut the trained whisker and re-glued it to the same or neighboring whisker stubs. The authors found that retention in the gap jumping task depended on the distance of the prosthetic whisker from the trained whisker. Moreover the authors demonstrated a quantitative correspondence between transfer in the task and physiological overlap of barrel cortex responses evoked by the two whiskers, suggesting that memories may not only be stored but also constrained by the topography of barrel cortex.

In conclusion, future experiments studying brain states and associative coupling need to accomplish a detailed monitoring and manipulation of cellular and sub-cellular processes in animals that perform tasks that optimally engage (and differentiate) brain states and cortico-cortical association. These will likely include mnemonic, and sensorimotor/cognitive tasks together with massive parallel monitoring of distributed neuronal activities and/or manipulating pathways and transmitter systems. Such an experiment has not been performed so far, but the recent achievements in this direction reviewed in this article, give cause for hope that the next couple of years will see significant progress in this endeavor.

## Acknowledgments

The authors of this article are members of the research unit *Barrel Cortex Function*, which is supported by the Swiss National Science Foundation (SNSF) and the Deutsche Forschungsgemeinschaft (DFG, FOR 1341; see <http://www.bacofun.medizin.uni-mainz.de/>). All authors contributed part of the manuscript. C.S. compiled the final version.

## References

- Adesnik, H., Scanziani, M., 2010. Lateral competition for cortical space by layer-specific horizontal circuits. *Nature* 464, 1155–1160.
- Ahissar, E., Staiger, J., 2010. *Scholarpedia* 5 (8) 7457.
- Allene, C., Cossart, R., 2010. Early NMDA receptor-driven waves of activity in the developing neocortex: physiological or pathological network oscillations? *Journal of Physiology* 588, 83–91.
- Alloway, K.D., 2008. Information processing streams in rodent barrel cortex: the differential functions of barrel and septal circuits. *Cerebral Cortex* 18, 979–989.
- Alloway, K.D., Zhang, M., Chakrabarti, S., 2004. Septal columns in rodent barrel cortex: Functional circuits for modulating whisking behavior. *Journal of Comparative Neurology* 480, 299–309.
- Amaral, D.G., Schumann, C.M., Nordahl, C.W., 2008. Neuroanatomy of autism. *Trends in Neuroscience* 31, 137–145.
- Andermann, M.L., Moore, C.I., 2006. A somatotopic map of vibrissa motion direction within a barrel column. *Nature Neuroscience* 9, 543–551.
- Angelucci, A., Levitt, J.B., Walton, E.J., Hupe, J.M., Bullier, J., Lund, J.S., 2002. Circuits for local and global signal integration in primary visual cortex. *Journal of Neuroscience* 22, 8633–8646.
- Angulo, M.C., Staiger, J.F., Rossier, J., Audinat, E., 2003. Distinct local circuits between neocortical pyramidal cells and fast-spiking inhibitory neurons in young adult rats. *Journal of Neurophysiology* 89, 943–953.

- Arabzadeh, E., Petersen, R.S., Diamond, M.E., 2003. Encoding of whisker vibration by rat barrel cortex neurons: implications for texture discrimination. *Journal of Neuroscience* 23, 9146–9154.
- Armstrong-James, M., Callahan, C.A., Friedman, M.A., 1991. Thalamo-cortical processing of vibrissal information in the rat. I. Intracortical origins of surround but not centre-receptive fields of layer IV neurones in the rat S1 barrel field cortex. *Journal of Comparative Neurology* 303, 193–210.
- Armstrong-James, M., Fox, K., Das-Gupta, A., 1992. Flow of excitation within rat barrel cortex on striking a single vibrissa. *Journal of Neurophysiology* 68, 1345–1358.
- Aronoff, R., Matyas, F., Mateo, C., Ciron, C., Schneider, B., Petersen, C.C., 2010. Long-range connectivity of mouse primary somatosensory barrel cortex. *European Journal of Neuroscience* 31, 2221–2233.
- Ascoli, G.A., Alonso-Nanclares, L., Anderson, S.A., Barrionuevo, G., Benavides-Piccionne, R., Burkhalter, A., Buzsaki, G., Cauli, B., DeFelipe, J., Fairen, A., Feldmeyer, D., Fishell, G., Frégnac, Y., Freund, T.F., Gardner, D., Gardner, E.P., Goldberg, J.H., Helmstaedter, M., Hestrin, S., Karube, F., Kisvarday, Z.F., Lambolez, B., Lewis, D.A., Marin, O., Markram, H., Muñoz, A., Packer, A., Petersen, C.C., Rockland, K.S., Rossier, J., Rudy, B., Somogyi, P., Staiger, J.F., Tamas, G., Thomson, A.M., Toledo-Rodriguez, M., Wang, Y., West, D.C., Yuste, R., 2008. Petilla terminology: nomenclature of features of GABAergic inhibitory neurons of the cerebral cortex. *Nature Reviews Neuroscience* 9, 557–568.
- Bartho, P., Freund, T.F., ACSady, L., 2002. Selective GABAergic innervation of thalamic nuclei from zona incerta. *European Journal of Neuroscience* 16, 999–1014.
- Bayraktar, T., Welker, E., Freund, T.F., Zilles, K., Staiger, J.F., 2000. Neurons immunoreactive for vasoactive intestinal polypeptide in the rat primary somatosensory cortex: morphology and spatial relationship to barrel-related columns. *Journal of Comparative Neurology* 420, 291–304.
- Beierlein, M., Gibson, J.R., Connors, B.W., 2003. Two dynamically distinct inhibitory networks in layer 4 of the neocortex. *Journal of Neurophysiology* 90, 2987–3000.
- Ben-Ari, Y., Woodin, M.A., Sernagor, E., Cancedda, L., Vinay, L., Rivera, C., Legendre, P., Luhmann, H.J., Bordey, A., Wenner, P., Fukuda, A., Van den Pol, A.N., Gaiarsa, J.L., Cherubini, E., 2012. Refuting the challenges of the developmental shift of polarity of GABA actions: GABA more exciting than ever! *Frontiers in Cellular Neuroscience* 6, 35.
- Bender, K.J., Rangel, J., Feldman, D.E., 2003. Development of columnar topography in the excitatory layer 4 to layer 2/3 projection in rat barrel cortex. *Journal of Neuroscience* 23, 8759–8770.
- Benison, A.M., Rector, D.M., Barth, D.S., 2007. Hemispheric mapping of secondary somatosensory cortex in the rat. *Journal of Neurophysiology* 97, 200–207.
- Berger, T.K., Perin, R., Silberberg, G., Markram, H., 2009. Frequency-dependent disinaptic inhibition in the pyramidal network: a ubiquitous pathway in the developing rat neocortex. *Journal of Physiology* 587, 5411–5425.
- Bock, D.D., Lee, W.C., Kerlin, A.M., Andermann, M.L., Hood, G., Wetzel, A.W., Yurgenson, S., Soucy, E.R., Kim, H.S., Reid RC, 2011. Network anatomy and in vivo physiology of visual cortical neurons. *Nature* 471 (March (7337)), 177–182.
- Bokor, H., Frere, S.G., Eyre, M.D., Slezia, A., Ulbert, I., ACSady, L., 2005. Selective GABAergic control of higher-order thalamic relays. *Neuron* 45, 929–940.
- Bolz, J., Gilbert, C.D., Wiesel, T.N., 1989. Pharmacological analysis of cortical circuitry. *Trends in Neuroscience* 12, 292–296.
- Bosman, L.W., Houweling, A.R., Owens, C.B., Tanke, N., Shevchouk, O.T., Rahmati, N., Teunissen, W.H., Ju, C., Gong, W., Koekkoek, S.K., De Zeeuw, C.I., 2011. Anatomical pathways involved in generating and sensing rhythmic whisker movements. *Frontiers in Integrative Neuroscience* 5, 53.
- Bourassa, J., Pinaut, D., Deschênes, M., 1995. Corticothalamic projections from the cortical barrel field to the somatosensory thalamus in rats: a single-fibre study using biocytin as an anterograde tracer. *European Journal of Neuroscience* 7, 19–30.
- Brecht, M., 2007. Barrel cortex and whisker-mediated behaviors. *Current Opinion in Neurobiology* 17, 408–416.
- Brecht, M., Krauss, A., Muhammad, S., Sinai-Esfahani, L., Bellanca, S., Margrie, T.W., 2004. Organization of rat vibrissa motor cortex and adjacent areas according to cytoarchitectonics, microstimulation, and intracellular stimulation of identified cells. *Journal of Comparative Neurology* 479, 360–373.
- Brecht, M., Roth, A., Sakmann, B., 2003. Dynamic receptive fields of reconstructed pyramidal cells in layers 3 and 2 of rat somatosensory barrel cortex. *Journal of Physiology* 553, 243–265.
- Brecht, M., Sakmann, B., 2002a. Dynamic representation of whisker deflection by synaptic potentials in spiny stellate and pyramidal cells in the barrels and septa of layer 4 rat somatosensory cortex. *Journal of Physiology* 543, 49–70.
- Brecht, M., Sakmann, B., 2002b. Whisker maps of neuronal subclasses of the rat ventral posterior medial thalamus, identified by whole-cell voltage recording and morphological reconstruction. *Journal of Physiology* 538, 495–515.
- Briggs, F., 2010. Organizing principles of cortical layer 6. *Frontiers in Neural Circuits* 4, 3.
- Bruno, R.M., Hahn, T.T., Wallace, D.J., de Kock, C.P., Sakmann, B., 2009. Sensory experience alters specific branches of individual corticocortical axons during development. *Journal of Neuroscience* 29, 3172–3181.
- Bruno, R.M., Sakmann, B., 2006. Cortex is driven by weak but synchronously active thalamocortical synapses. *Science* 312, 1622–1627.
- Bureau, I., von Saint, P.F., Svoboda, K., 2006. Interdigitated palelemniscal and lemniscal pathways in the mouse barrel cortex. *PLoS Biology* 4, e382.
- Butovas, S., Hormuzdi, S.G., Monyer, H., Schwarz, C., 2006. Effects of electrically coupled inhibitory networks on local neuronal responses to intracortical microstimulation. *Journal of Neurophysiology* 96, 1227–1236.
- Butovas, S., Schwarz, C., 2007. Detection psychophysics of intracortical microstimulation in rat primary somatosensory cortex. *European Journal of Neuroscience* 25, 2161–2169.
- Buzsaki, G., Bickford, R.G., Ponomareff, G., Thal, L.J., Mandel, R., Gage, F.H., 1988. Nucleus basalis and thalamic control of neocortical activity in the freely moving rat. *Journal of Neuroscience* 8, 4007–4026.
- Cardin, J.A., Carlen, M., Meletis, K., Knoblich, U., Zhang, F., Deisseroth, K., Tsai, L.H., Moore, C.I., 2009. Driving fast-spiking cells induces gamma rhythm and controls sensory responses. *Nature* 459, 663–667.
- Carvell, G.E., Simons, D.J., 1995. Task- and subject-related differences in sensorimotor behavior during active touch. *Somatosensory and Motor Research* 12, 1–9.
- Carvell, G.E., Simons, D.J., 1988. Membrane potential changes in rat Sml cortical neurons evoked by controlled stimulation of mystacial vibrissae. *Brain Research* 448, 186–191.
- Carvell, G.E., Simons, D.J., 1990. Biometric analyses of vibrissal tactile discrimination in the rat. *Journal of Neuroscience* 10, 2638–2648.
- Castro-Alamancos, M.A., 2004. Absence of rapid sensory adaptation in neocortex during information processing states. *Neuron* 41, 455–464.
- Castro-Alamancos, M.A., Oldford, E., 2002. Cortical sensory suppression during arousal is due to the activity-dependent depression of thalamocortical synapses. *J Physiol* 541, 319–331.
- Celikel, T., Szostak, V.A., Feldman, D.E., 2004. Modulation of spike timing by sensory deprivation during induction of cortical map plasticity. *Nature Neuroscience* 7, 534–541.
- Chakrabarti, S., Alloway, K.D., 2006. Differential origin of projections from SI barrel cortex to the whisker representations in SII and MI. *Journal of Comparative Neurology* 498, 624–636.
- Chakrabarti, S., Zhang, M., Alloway, K.D., 2008. MI neuronal responses to peripheral whisker stimulation: relationship to neuronal activity in SI barrels and septa. *Journal of Neurophysiology* 100, 50–63.
- Chmielowska, J., Carvell, G.E., Simons, D.J., 1989. Spatial organization of thalamo-cortical and corticothalamic projection systems in rat Sml barrel cortex. *Journal of Comparative Neurology* 285, 325–338.
- Christophe, E., Roebuck, A., Staiger, J.F., Lavery, D.J., Charpak, S., Audinat, E., 2002. Two types of nicotinic receptors mediate an excitation of neocortical layer I inhibitory neurons. *Journal of Neurophysiology* 88, 1318–1327.
- Chung, S., Li, X., Nelson, S.B., 2002. Short-term depression at thalamocortical synapses contributes to rapid adaptation of cortical sensory responses in vivo. *Neuron* 34, 437–446.
- Clark, G.A., McCormick, D.A., Lavond, D.G., Thompson, R.F., 1984. Effects of lesions of cerebellar nuclei on conditioned behavioral and hippocampal neuronal responses. *Brain Research* 291, 125–136.
- Constantinople, C.M., Bruno, R.M., 2011. Effects and mechanisms of wakefulness on local cortical networks. *Neuron* 69, 1061–1068.
- Courchesne, E., Pierce, K., Schumann, C.M., Redcay, E., Buckwalter, J.A., Kennedy, D.P., Morgan, J., 2007. Mapping early brain development in autism. *Neuron* 56, 399–413.
- Crandall, J.E., Korde, M., Caviness Jr., V.S., 1986. Somata of layer V projection neurons in the mouse barrelfield cortex are in preferential register with the sides and septa of the barrels. *Neuroscience Letters* 67, 19–24.
- Crochet, S., Petersen, C.C., 2006. Correlating whisker behavior with membrane potential in barrel cortex of awake mice. *Nature Neuroscience* 9, 608–610.
- Cruikshank, S.J., Lewis, T.J., Connors, B.W., 2007. Synaptic basis for intense thalamocortical activation of feedforward inhibitory cells in neocortex. *Nature Neuroscience* 10, 462–468.
- David, C., Schleicher, A., Zschratler, W., Staiger, J.F., 2007. The innervation of parvalbumin-containing inhibitory neurons by VIP-immunopositive inhibitory neurons in the primary somatosensory cortex of the adult rat. *European Journal of Neuroscience* 25, 2329–2340.
- Daw, M.I., Ashby, M.C., Isaac, J.T., 2007. Coordinated developmental recruitment of latent fast spiking inhibitory neurons in layer IV barrel cortex. *Nature Neuroscience* 10, 453–461.
- de Kock, C.P., Bruno, R.M., Spors, H., Sakmann, B., 2007. Layer- and cell-type-specific suprathreshold stimulus representation in rat primary somatosensory cortex. *Journal of Physiology* 581, 139–154.
- de Kock, C.P., Sakmann, B., 2008. High frequency action potential bursts (> or =100 Hz) in L2/3 and L5B thick tufted neurons in anaesthetized and awake rat primary somatosensory cortex. *Journal of Physiology* 586, 3353–3364.
- de Kock, C.P., Sakmann, B., 2009. Spiking in primary somatosensory cortex during natural whisking in awake head-restrained rats is cell-type specific. *Proceedings of the National Academy of Science USA* 106, 16446–16450.
- Deschênes, M., Veinante, P., Zhang, Z.W., 1998. The organization of corticothalamic projections: reciprocity versus parity. *Brain Research Review* 28, 286–308.
- Diamond, M.E., Huang, W., Ebner, F.F., 1994. Laminar comparison of somatosensory cortical plasticity. *Science* 265, 1885–1888.
- Diamond, D.M., Weinberger, N.M., 1986. Classical conditioning rapidly induces specific changes in frequency receptive fields of single neurons in secondary and ventral ectosylvian auditory cortical fields. *Brain Research* 372, 357–360.
- Diamond, D.M., Weinberger, N.M., 1989. Role of context in the expression of learning-induced plasticity of single neurons in auditory cortex. *Behavioral Neuroscience* 103, 471–494.
- Diamond, M.E., von Heimendahl, M., Knutsen, P.M., Kleinfeld, D., Ahissar, E., 2008. 'Where' and 'what' in the whisker sensorimotor system. *Nature Reviews Neuroscience* 9, 601–612.

- Disterhoft, J.F., Stuart, D.K., 1976. Trial sequence of changed unit activity in auditory system of alert rat during conditioned response acquisition and extinction. *Journal of Neurophysiology* 39, 266–281.
- Douglas, R.J., Martin, K.A., 2004. Neuronal circuits of the neocortex. *Annual Review of Neuroscience* 27, 419–451.
- Douglas, R.J., Martin, K.A., 2007. Mapping the matrix: the ways of neocortex. *Neuron* 56, 226–238.
- Douglas, R.J., Martin, K.A.C., 1991. A functional microcircuit for cat visual cortex. *Journal of Physiology (London)* 440, 735–769.
- Dumitriu, D., Cossart, R., Huang, J., Yuste, R., 2007. Correlation between axonal morphologies and synaptic input kinetics of inhibitory neurons from mouse visual cortex. *Cerebral Cortex* 17, 81–91.
- Dupont, E., Hanganu, I.L., Kilb, W., Hirsch, S., Luhmann, H.J., 2006. Rapid developmental switch in the mechanisms driving early cortical columnar networks. *Nature* 439, 79–83.
- Ebara, S., Kumamoto, K., Matsuura, T., Mazurkiewicz, J.E., Rice, F.L., 2002. Similarities and differences in the innervation of mystacial vibrissal follicle-sinus complexes in the rat and cat: a confocal microscopic study. *Journal of Comparative Neurology* 449, 103–119.
- Egger, V., Nevian, T., Bruno, R.M., 2008. Subcolumnar dendritic and axonal organization of spiny stellate and star pyramid neurons within a barrel in rat somatosensory cortex. *Cerebral Cortex* 18, 876–889.
- Eggermann, E., Feldmeyer, D., 2009. Cholinergic filtering in the recurrent excitatory microcircuit of cortical layer 4. *Proceedings of the National Academy of Science USA* 106, 11753–11758.
- Ego-Stengel, B., Shulz, D.E., Haidarliu, S., Sosnik, R., Ahissar, E., 2001. Acetylcholine-dependent induction and expression of functional plasticity in the barrel cortex of the adult rat. *Journal of Neurophysiology* 86, 422–437.
- Fanselow, E.E., Nicolelis, M.A., 1999. Behavioral modulation of tactile responses in the rat somatosensory system. *Journal of Neuroscience* 19, 7603–7616.
- Feldman, D.E., Brecht, M., 2005. Map plasticity in somatosensory cortex. *Science* 310, 810–815.
- Feldmeyer, D., 2012. Excitatory neuronal connectivity in the barrel cortex. *Frontiers in Neuroanatomy* 6, 24.
- Feldmeyer, D., Egger, V., Lübke, J., Sakmann, B., 1999. Reliable synaptic connections between pairs of excitatory layer 4 neurones within a single ‘barrel’ of developing rat somatosensory cortex. *Journal of Physiology (London)* 521, 169–190.
- Feldmeyer, D., Lübke, J., Sakmann, B., 2006. Efficacy and connectivity of intracolumnar pairs of layer 2/3 pyramidal cells in the barrel cortex of juvenile rats. *Journal of Physiology* 575, 583–602.
- Feldmeyer, D., Lübke, J., Silver, R.A., Sakmann, B., 2002. Synaptic connections between layer 4 spiny neurone – layer 2/3 pyramidal cells pairs in juvenile rat barrel cortex: physiology and anatomy of interlaminar signalling within a cortical column. *Journal of Physiology (London)* 538 (3), 803–822.
- Feldmeyer, D., Radnikow, G., 2009. Developmental alterations in the functional properties of excitatory neocortical synapses. *Journal of Physiology* 587, 1889–1896.
- Feldmeyer, D., Roth, A., Sakmann, B., 2005. Monosynaptic connections between pairs of spiny stellate cells in layer 4 and pyramidal cells in layer 5A indicate that lemniscal and paralemniscal afferent pathways converge in the infragranular somatosensory cortex. *Journal of Neuroscience* 25, 3423–3431.
- Felleman, D.J., van Essen, D.C., 1991. Distributed hierarchical processing in the primate cerebral cortex. *Cerebral Cortex* 1, 1–47.
- Ferezou, I., Bolea, S., Petersen, C.C., 2006. Visualizing the cortical representation of whisker touch: voltage-sensitive dye imaging in freely moving mice. *Neuron* 50, 617–629.
- Ferezou, I., Haiss, F., Gentet, L.J., Aronoff, R., Weber, B., Petersen, C.C., 2007. Spatiotemporal dynamics of cortical sensorimotor integration in behaving mice. *Neuron* 56, 907–923.
- Fox, K., 1992. A critical period for experience-dependent synaptic plasticity in rat barrel cortex. *Journal of Neuroscience* 12, 1826–1838.
- Fox, K., 2002. Anatomical pathways and molecular mechanisms for plasticity in the barrel cortex. *Neuroscience* 111, 799–814.
- Fox, K., 2008. *Barrel Cortex*. Cambridge University Press, Cambridge.
- Fox, K., Wright, N., Wallace, H., Glazewski, S., 2003. The origin of cortical surround receptive fields studied in the barrel cortex. *Journal of Neuroscience* 23, 8380–8391.
- Frick, A., Feldmeyer, D., Sakmann, B., 2007. Postnatal development of synaptic transmission in local networks of L5A pyramidal neurons in rat somatosensory cortex. *Journal of Physiology* 585, 103–116.
- Fujisawa, S., Amarasingham, A., Harrison, M.T., Buzsáki, G., 2008. Behavior-dependent short-term assembly dynamics in the medial prefrontal cortex. *Nature Neuroscience* 11, 823–833.
- Fukuchi-Shimogori, T., Grove, E.A., 2001. Neocortex patterning by the secreted signaling molecule FGF8. *Science* 294, 1071–1074.
- Furuta, T., Kaneko, T., Deschênes, M., 2009a. Septal neurons in barrel cortex derive their receptive field input from the lemniscal pathway. *Journal of Neuroscience* 29, 4089–4095.
- Furuta, T., Kaneko, T., Deschênes, M., 2009b. Septal neurons in barrel cortex derive their receptive field input from the lemniscal pathway. *Journal of Neuroscience* 29, 4089–4095.
- Furuta, T., Timofeeva, E., Nakamura, K., Okamoto-Furuta, K., Togo, M., Kaneko, T., Deschênes, M., 2008. Inhibitory gating of vibrissal inputs in the brainstem. *Journal of Neuroscience* 28, 1789–1797.
- Furuta, T., Urbain, N., Kaneko, T., Deschênes, M., 2010. Corticofugal control of vibrissa-sensitive neurons in the interpolaris nucleus of the trigeminal complex. *Journal of Neuroscience* 30, 1832–1838.
- Fuster, J.M., 2009. Cortex and memory: emergence of a new paradigm. *Journal of Cognitive Neuroscience* 21, 2047–2072.
- Gabernet, L., Jadhav, S.P., Feldman, D.E., Carandini, M., Scanziani, M., 2005. Somatosensory integration controlled by dynamic thalamocortical feed-forward inhibition. *Neuron* 48, 315–327.
- Galvez, R., Weible, A.P., Disterhoft, J.F., 2007. Cortical barrel lesions impair whisker-CS trace eyeblink conditioning. *Learning and Memory* 14, 94–100.
- Galvez, R., Weiss, C., Weible, A.P., Disterhoft, J.F., 2006. Vibrissa-signaled eyeblink conditioning induces somatosensory cortical plasticity. *Journal of Neuroscience* 26, 6062–6068.
- Garabedian, C.E., Jones, S.R., Merzenich, M.M., Dale, A., Moore, C.I., 2003. Band-pass response properties of rat SI neurons. *Journal of Neurophysiology* 90, 1379–1391.
- Gaspar, P., Cases, O., Maroteaux, L., 2003. The developmental role of serotonin: news from mouse molecular genetics. *Nature Reviews Neuroscience* 4, 1002–1012.
- Gelman, D.M., Marin, O., 2010. Generation of inhibitory neuron diversity in the mouse cerebral cortex. *European Journal of Neuroscience* 31, 2136–2141.
- Gentet, L.J., Avermann, M., Matyas, F., Staiger, J.F., Petersen, C.C., 2010. Membrane potential dynamics of GABAergic neurons in the barrel cortex of behaving mice. *Neuron* 65, 422–435.
- Gentet, L.J., Kremer, Y., Taniguchi, H., Huang, Z.J., Staiger, J.F., Petersen, C.C.H., 2012. Unique functional properties of somatostatin-expressing GABAergic neurons in mouse barrel cortex. *Nature Neuroscience* 15, 607–612.
- Gerdjikov, T.V., Bergner, C.G., Stüttgen, M.C., Waiblinger, C., Schwarz, C., 2010. Discrimination of vibrotactile stimuli in the rat whisker system: behavior and neurometrics. *Neuron* 65, 530–540.
- Ghose, G.M., Yang, T., Maunsell, J.H., 2002. Physiological correlates of perceptual learning in monkey V1 and V2. *Journal of Neurophysiology* 87, 1867–1888.
- Gibson, J.M., Welker, W.L., 1983. Quantitative studies of stimulus coding in first-order vibrissa afferents of rats. 2. Adaptation and coding of stimulus parameters. *Somatosensory and Motor Research* 1, 95–117.
- Gil, Z., Connors, B.W., Amitai, Y., 1997. Differential regulation of neocortical synapses by neuromodulators and activity. *Neuron* 19, 679–686.
- Gilbert, C.D., 1983. Microcircuitry of the visual cortex. *Annual Review of Neuroscience* 6, 217–247.
- Gilbert, C.D., Wiesel, T.N., 1983. Clustered intrinsic connections in cat visual cortex. *Journal of Neuroscience* 3, 1116–1133.
- Golbs, A., Nimmervoll, B., Sun, J.J., Sava, I.E., Luhmann, H.J., 2011. Control of programmed cell death by distinct electrical activity patterns. *Cerebral Cortex* 21, 1192–1202.
- Goldreich, D., Kyriazi, H.T., Simons, D.J., 1999. Functional independence of layer IV barrels in rodent somatosensory cortex. *Journal of Neurophysiology* 82, 1311–1316.
- Golshani, P., Goncalves, J.T., Khoshkhou, S., Mostany, R., Smirnakis, S., Portera-Cailliau, C., 2009. Internally mediated developmental desynchronization of neocortical network activity. *Journal of Neuroscience* 29, 10890–10899.
- Greenberg, D.S., Houweling, A.R., Kerr, J.N., 2008. Population imaging of ongoing neuronal activity in the visual cortex of awake rats. *Nature Neuroscience* 11, 749–751.
- Grewe, B.F., Helmchen, F., 2009. Optical probing of neuronal ensemble activity. *Current Opinion in Neurobiology* 19, 520–529.
- Groh, A., de Kock, C.P., Wimmer, V.C., Sakmann, B., Kuner, T., 2008. Driver or coincidence detector: modal switch of a corticothalamic giant synapse controlled by spontaneous activity and short-term depression. *Journal of Neuroscience* 28, 9652–9663.
- Guic-Robles, E., Jenkins, W.M., Bravo, H., 1992. Vibrissal roughness discrimination is barrelcortex-dependent. *Behavioural Brain Research* 48, 145–152.
- Guic-Robles, E., Valdivieso, C., Guajardo, G., 1989. Rats can learn a roughness discrimination using only their vibrissal system. *Behavioural Brain Research* 31, 285–289.
- Guillery, R.W., Sherman, S.M., 2002. Thalamic relay functions and their role in corticocortical communication: generalizations from the visual system. *Neuron* 33, 163–175.
- Gulledge, A.T., Kawaguchi, Y., 2007. Phasic cholinergic signaling in the hippocampus: functional homology with the neocortex? *Hippocampus* 17, 327–332.
- Gulledge, A.T., Stuart, G.J., 2005. Cholinergic inhibition of neocortical pyramidal neurons. *Journal of Neuroscience* 25, 10308–10320.
- Hall, R.D., Lindholm, E.P., 1974. Organization of motor and somatosensory neocortex in the albino rat. *Brain Research* 66, 23–38.
- Hanganu, I.L., Luhmann, H.J., 2004. Functional nicotinic acetylcholine receptors on subplate neurons in neonatal rat somatosensory cortex. *Journal of Neurophysiology* 92, 189–198.
- Hanganu, I.L., Okabe, A., Lessmann, V., Luhmann, H.J., 2009. Cellular mechanisms of subplate-driven and cholinergic input-dependent network activity in the neonatal rat somatosensory cortex. *Cerebral Cortex* 19, 89–105.
- Harris, J.A., Petersen, R.S., Diamond, M.E., 1999. Distribution of tactile learning and its neural basis. *Proceedings of the National Academy of Science USA* 96, 7587–7591.
- Harris, R.M., Woolsey, T.A., 1983. Computer-assisted analyses of barrel neuron axons and their putative synaptic contacts. *Journal of Comparative Neurology* 220, 63–79.
- Hartings, J.A., Temereanca, S., Simons, D.J., 2003. Processing of periodic whisker deflections by neurons in the ventroposterior medial and thalamic reticular nuclei. *Journal of Neurophysiology* 90, 3087–3094.
- Hartmann, M.J., Johnson, N.J., Towal, R.B., Assad, C., 2003. Mechanical characteristics of rat vibrissae: resonant frequencies and damping in isolated whiskers and in the awake behaving animal. *Journal of Neuroscience* 23, 6510–6519.

- Harvey, C.D., Coen, P., Tank, D.W., 2012. Choice-specific sequences in parietal cortex during a virtual-navigation decision task. *Nature* 484, 62–68.
- Heck, N., Golbs, A., Riedemann, T., Sun, J.J., Lessmann, V., Luhmann, H.J., 2008. Activity-dependent regulation of neuronal apoptosis in neonatal mouse cerebral cortex. *Cerebral Cortex* 18, 1335–1349.
- Helmchen, F., Denk, W., 2005. Deep tissue two-photon microscopy. *Nature Methods* 2, 932–940.
- Helmstaedter, M., Feldmeyer, D., 2010. Axons predict neuronal connectivity within and between cortical columns and serve as primary classifiers of inhibitory neurons in a cortical column. In: Feldmeyer, D., Lübke, J.H. (Eds.), *New Aspects of Axonal Structure and Function*. Springer, New York, Heidelberg, pp. 141–155.
- Helmstaedter, M., de Kock, C.P., Feldmeyer, D., Bruno, R.M., Sakmann, B., 2007. Reconstruction of an average cortical column in silico. *Brain Research Reviews* 55, 193–203.
- Helmstaedter, M., Sakmann, B., Feldmeyer, D., 2009a. L2/3 inhibitory neuron groups defined by multiparameter analysis of axonal projection, dendritic geometry, and electrical excitability. *Cerebral Cortex* 19, 951–962.
- Helmstaedter, M., Sakmann, B., Feldmeyer, D., 2009b. Neuronal correlates of local, lateral, and translaminar inhibition with reference to cortical columns. *Cerebral Cortex* 19, 926–937.
- Helmstaedter, M., Sakmann, B., Feldmeyer, D., 2009c. The relation between dendritic geometry, electrical excitability, and axonal projections of L2/3 inhibitory neurons in rat barrel cortex. *Cerebral Cortex* 19, 938–950.
- Helmstaedter, M., Staiger, J.F., Sakmann, B., Feldmeyer, D., 2008. Efficient recruitment of layer 2/3 inhibitory neurons by layer 4 input in single columns of rat somatosensory cortex. *Journal of Neuroscience* 28, 8273–8284.
- Henderson, T.A., Jacquin, M.F., 1995. What makes subcortical barrels? In: Jones, E.G., Diamond, I.T. (Eds.), *Cerebral Cortex, the Barrel Cortex of Rodents*, vol. 11. Plenum, New York, pp. 123–187.
- Hentschke, H., Haiss, F., Schwarz, C., 2006. Central signals rapidly switch tactile processing in rat barrel cortex during whisker movements. *Cerebral Cortex* 16, 1142–1156.
- Hoogland, P.V., Wouterlood, F.G., Welker, E., Van der Loos, H., 1991. Ultrastructure of giant and small thalamic terminals of cortical origin: a study of the projections from the barrel cortex in mice using Phaseolus vulgaris leuco-agglutinin (PHA-L). *Experimental Brain Research* 87, 159–172.
- Hooks, B.M., Hires, S.A., Zhang, Y.X., Huber, D., Petreanu, L., Svoboda, K., Shepherd, G.M., 2011. Laminar analysis of excitatory local circuits in vibrissal motor and sensory cortical areas. *PLoS Biology* 9, e1000572.
- Houser, C.R., Crawford, G.D., Salvaterra, P.M., Vaughn, J.E., 1985. Immunocytochemical localization of choline acetyltransferase in rat cerebral cortex: a study of cholinergic neurons and synapses. *Journal of Comparative Neurology* 234, 17–34.
- Houweling, A.R., Brecht, M., 2008. Behavioural report of single neuron stimulation in somatosensory cortex. *Nature* 451, 65–68.
- Houweling, A.R., Doron, G., Voigt, B.C., Herfst, L.J., Brecht, M., 2010. Nanostimulation: manipulation of single neuron activity by juxtacellular current injection. *Journal of Neurophysiology* 103, 1696–1704.
- Huber, D., Gutnisky, D.A., Peron, S., O'Connor, D.H., Wiegert, J.S., Tian, L., Oertner, T.G., Looger, L.L., Svoboda, K., 2012. Multiple dynamic representations in the motor cortex during sensorimotor learning. *Nature* 484, 473–478.
- Huber, D., Petreanu, L., Ghitani, N., Ranade, S., Hromadka, T., Mainen, Z., Svoboda, K., 2008. Sparse optical microstimulation in barrel cortex drives learned behaviour in freely moving mice. *Nature* 451, 61–64.
- Hutson, K.A., Masterton, R.B., 1986. The sensory contribution of a single vibrissa's cortical barrel. *Journal of Neurophysiology* 56, 1196–1223.
- Jacquin, M.F., Chiaia, N.L., Haring, J.H., Rhoades, R.W., 1990. Intersubnuclear connections within the rat trigeminal brainstem complex. *Somatosensory and Motor Research* 7, 399–420.
- Jacquin, M.F., Rhoades, R.W., 1990. Cell structure and response properties in the trigeminal subnucleus oralis. *Somatosensory and Motor Research* 7, 265–288.
- Jacquin, M.F., Barcia, M., Rhoades, R.W., 1989a. Structure–function relationships in rat brainstem subnucleus interpolaris: IV. Projection neurons. *Journal of Comparative Neurology* 282, 45–62.
- Jacquin, M.F., Golden, J., Rhoades, R.W., 1989b. Structure–function relationships in rat brainstem subnucleus interpolaris: III. Local circuit neurons. *Journal of Comparative Neurology* 282, 24–44.
- Jadhav, S.P., Wolfe, J., Feldman, D.E., 2009a. Sparse temporal coding of elementary tactile features during active whisker sensation. *Nature Neuroscience* 12, 792–800.
- Kampa, B.M., Letzkus, J.J., Stuart, G.J., 2006. Cortical feed-forward networks for binding different streams of sensory information. *Nature Neuroscience* 9, 1472–1473.
- Kang, J., Huguenard, J.R., Prince, D.A., 1996. Development of BK channels in neocortical pyramidal neurons. *Journal of Neurophysiology* 76, 188–198.
- Kanold, P.O., Luhmann, H.J., 2010. The subplate and early cortical circuits. *Annual Review of Neuroscience* 33, 23–48.
- Karagiannis, A., Gallopini, T., David, C., Battaglia, D., Geoffroy, H., Rossier, J., Hillman, E.M., Staiger, J.F., Cauli, B., 2009. Classification of NPY-expressing neocortical inhibitory neurons. *Journal of Neuroscience* 29, 3642–3659.
- Katz, Y., Heiss, J.E., Lampl, I., 2006. Cross-whisker adaptation of neurons in the rat barrel cortex. *Journal of Neuroscience* 26, 13363–13372.
- Kawaguchi, Y., Kubota, Y., 1997. GABAergic cell subtypes and their synaptic connections in rat frontal cortex. *Cerebral Cortex* 7, 476–486.
- Kerr, J.N., de Kock, C.P., Greenberg, D.S., Bruno, R.M., Sakmann, B., Helmchen, F., 2007. Spatial organization of neuronal population responses in layer 2/3 of rat barrel cortex. *Journal of Neuroscience* 27, 13316–13328.
- Khatiri, V., Hartings, J.A., Simons, D.J., 2004. Adaptation in thalamic barreloid and cortical barrel neurons to periodic whisker deflections varying in frequency and velocity. *Journal of Neurophysiology* 92, 3244–3254.
- Khazipov, R., Luhmann, H.J., 2006. Early patterns of electrical activity in the developing cerebral cortex of human and rodents. *Trends in Neurosciences* 29, 414–418.
- Khazipov, R., Sirota, A., Leinekugel, X., Holmes, G.L., Ben-Ari, Y., Buzsáki, G., 2004. Early motor activity drives spindle bursts in the developing somatosensory cortex. *Nature* 432, 758–761.
- Kilb, W., 2011. Development of the GABAergic system from birth to adolescence. *The Neuroscientist*, <http://dx.doi.org/10.1177/1073858411422114>.
- Kilb, W., Kirischuk, S., Luhmann, H.J., 2011. Electrical activity patterns and the functional maturation of the neocortex. *European Journal of Neuroscience* 34, 1677–1686.
- Killackey, H.P., Sherman, S.M., 2003. Corticothalamic projections from the rat primary somatosensory cortex. *Journal of Neuroscience* 23, 7381–7384.
- Kim, U., Ebner, F.F., 1999. Barrels and septa: separate circuits in rat barrels field cortex. *Journal of Comparative Neurology* 408, 489–505.
- Kimura, F., Itami, C., Ikezoe, K., Tamura, H., Fujita, I., Yanagawa, Y., Obata, K., Ohshima, M., 2010. Fast activation of feedforward inhibitory neurons from thalamic input and its relevance to the regulation of spike sequences in the barrel cortex. *Journal of Physiology* 588, 2769–2787.
- Kitzes, L.M., Farley, G.R., Starr, A., 1978. Modulation of auditory cortex unit activity during the performance of a conditioned response. *Experimental Neurology* 62, 678–697.
- Knutsen, P.M., Pietr, M., Ahissar, E., 2006. Haptic object localization in the vibrissal system: behavior and performance. *Journal of Neuroscience* 26, 8451–8464.
- Kölbl, C.O., Helmstaedter, M., Lübke, J.H., Feldmeyer, D., 2010. Fast spiking inhibitory neurons in layer 4 of rat barrel cortex. *Acta Physiologica (Oxford)* 198, 90.
- Koralek, K.A., Olavarria, J., Killackey, H.P., 1990. Areal and laminar organization of corticocortical projections in the rat somatosensory cortex. *Journal of Comparative Neurology* 299, 133–150.
- Kozloski, J., Hamzei-Sichani, F., Yuste, R., 2001. Stereotyped position of local synaptic targets in neocortex. *Science* 293, 868–872.
- Kremer, Y., Leger, J.F., Goodman, D., Brette, R., Bourdieu, L., 2011. Late emergence of the vibrissa direction selectivity map in the rat barrel cortex. *Journal of Neuroscience* 31, 10689–10700.
- Kristt, D.A., 1979. Acetylcholinesterase-containing neurons of layer VIB in immature neocortex: possible component of an early formed intrinsic cortical circuit. *Anatomy and Embryology (Berlin)* 157, 217–226.
- Kristt, D.A., Waldman, J.V., 1981. The origin of the acetylcholinesterase-rich afferents to layer IV of infant somatosensory cortex. A histochemical analysis following lesions. *Anatomy and Embryology (Berlin)* 163, 31–41.
- Kumar, P., Ohana, O., 2008. Inter- and intralaminar subcircuits of excitatory and inhibitory neurons in layer 6a of the rat barrel cortex. *Journal of Neurophysiology* 100, 1909–1922.
- Kwegyir-Afful, E.E., Bruno, R.M., Simons, D.J., Keller, A., 2005. The role of thalamic inputs in surround receptive fields of barrel neurons. *Journal of Neuroscience* 25, 5926–5934.
- Langer, D., Helmchen, F., 2012. Post hoc immunostaining of GABAergic neuronal subtypes following in vivo two-photon calcium imaging in mouse neocortex. *Pflügers Archiv* 463 (February (2)), 339–354.
- Lavallée, P., Urbain, N., Dufresne, C., Bokor, H., Acsady, L., Deschênes, M., 2005. Feedforward inhibitory control of sensory information in higher-order thalamic nuclei. *Journal of Neuroscience* 25, 7489–7498.
- Lee, A.K., Manns, I.D., Sakmann, B., Brecht, M., 2006. Whole-cell recordings in freely moving rats. *Neuron* 51, 399–407.
- Lee, S., Carvell, G.E., Simons, D.J., 2008. Motor modulation of afferent somatosensory circuits. *Nature Neuroscience* 11, 1430–1438.
- Lee, S., Hjerling-Leffler, J., Zagna, E., Fishell, G., Rudy, B., 2010. The largest group of superficial neocortical GABAergic interneurons expresses ionotropic serotonin receptors. *Journal of Neuroscience* 30, 16796–16808.
- Lefort, S., Tomm, C., Floyd Sarria, J.C., Petersen, C.C., 2009. The excitatory neuronal network of the C2 barrel column in mouse primary somatosensory cortex. *Neuron* 61, 301–316.
- Lendvai, B., Stern, E.A., Chen, B., Svoboda, K., 2000. Experience-dependent plasticity of dendritic spines in the developing rat barrel cortex in vivo. *Nature* 404, 876–881.
- Lo, F.S., Guido, W., Erzurumlu, R.S., 1999. Electrophysiological properties and synaptic responses of cells in the trigeminal principal sensory nucleus of postnatal rats. *Journal of Neurophysiology* 82, 2765–2775.
- López-Bendito, G., Molnár, Z., 2003. Thalamocortical development: how are we going to get there? *Nature Reviews Neuroscience* 4, 276–289.
- Lübke, J., Egger, V., Sakmann, B., Feldmeyer, D., 2000. Columnar organization of dendrites and axons of single and synaptically coupled excitatory spiny neurons in layer 4 of the rat barrel cortex. *Journal of Neuroscience* 20, 5300–5311.
- Lübke, J., Feldmeyer, D., 2007. Excitatory signal flow and connectivity in a cortical column: focus on barrel cortex. *Brain Structure and Function* 212, 3–17.
- Lübke, J., Roth, A., Feldmeyer, D., Sakmann, B., 2003. Morphometric analysis of the columnar innervation domain of neurons connecting layer 4 and layer 2/3 of juvenile rat barrel cortex. *Cerebral Cortex* 13, 1051–1063.
- Luhmann, H.J., Kilb, W., Hanganu-Opatz, I.L., 2009. Subplate cells: amplifiers of neuronal activity in the developing cerebral cortex. *Frontiers in Neuroanatomy* 3, 19ff.
- Luhmann, H.J., Prince, D.A., 1991. Postnatal maturation of the GABAergic system in rat neocortex. *Journal of Neurophysiology* 65, 247–263.

- Lund, J.S., Yoshioka, T., Levitt, J.B., 1993. Comparison of intrinsic connectivity in different areas of macaque monkey cerebral cortex. *Cerebral Cortex* 3, 148–162.
- Lütcke, H., Murayama, M., Hahn, T., Margolis, D.J., Astori, S., Zum Alten Borgloh, S.M., Göbel, W., Yang, Y., Tang, W., Sprengel, S., Sprengel, R., Nagai, T., Miyawaki, A., Larkum, M.E., Helmchen, F., Hasan, M.T., 2010. Optical recording of neuronal activity with a genetically-encoded calcium indicator in anesthetized and freely moving mice. *Frontiers in Neural Circuits* 4, 9.
- Ma, P.M., Woosley, T.A., 1984. Cytoarchitectonic correlates of the vibrissae in the medullary trigeminal complex of the mouse. *Brain Research* 306, 374–379.
- Ma, Y., Hu, H., Berrebi, A.S., Mathers, P.H., Agmon, A., 2006. Distinct subtypes of somatostatin-containing neocortical inhibitory neurons revealed in transgenic mice. *Journal of Neuroscience* 26, 5069–5082.
- Manns, I.D., Sakmann, B., Brecht, M., 2004. Sub- and suprathreshold receptive field properties of pyramidal neurons in layers 5A and 5B of rat somatosensory barrel cortex. *Journal of Physiology* 556, 601–622.
- Mao, T., Kusefoglu, D., Hooks, B.M., Huber, D., Petreanu, L., Svoboda, K., 2011. Long-range neuronal circuits underlying the interaction between sensory and motor cortex. *Neuron* 72, 111–123.
- Maravall, M., Koh, I.Y., Lindquist, W.B., Svoboda, K., 2004a. Experience-dependent changes in basal dendritic branching of layer 2/3 pyramidal neurons during a critical period for developmental plasticity in rat barrel cortex. *Cerebral Cortex* 14, 655–664.
- Maravall, M., Stern, E.A., Svoboda, K., 2004b. Development of intrinsic properties and excitability of layer 2/3 pyramidal neurons during a critical period for sensory maps in rat barrel cortex. *Journal of Neurophysiology* 92, 144–156.
- Margolis, D.J., Lütcke, H., Schulz, K., Haiss, F., Weber, B., Kügler, S., Hasan, M.T., Helmchen, F., 2012. Reorganization of cortical population activity imaged throughout long-term sensory deprivation. *Nature Neuroscience* 15, 1539–1546.
- Markram, H., 2006. The blue brain project. *Nature Reviews Neuroscience* 7, 153–160.
- Markram, H., Lübke, J., Frotscher, M., Roth, A., Sakmann, B., 1997. Physiology and anatomy of synaptic connections between thick tufted pyramidal neurons in the developing rat neocortex. *Journal of Physiology (London)* 500, 409–440.
- Markram, H., Toledo-Rodriguez, M., Wang, Y., Gupta, A., Silberberg, G., Wu, C., 2004. Inhibitory neurons of the neocortical inhibitory system. *Nature Reviews Neuroscience* 5, 793–807.
- Mateo, C., Avermann, M., Gentet, L.J., Zhang, F., Deisseroth, K., Petersen, C.C., 2011. In vivo optogenetic stimulation of neocortical excitatory neurons drives brain-state-dependent inhibition. *Current Biology* 21, 1593–1602.
- Matyas, F., Sreenivasan, V., Marbach, F., Wacongne, C., Barsy, B., Mateo, C., Aronoff, R., Petersen, C.C., 2010. Motor control by sensory cortex. *Science* 330, 1240–1243.
- Mauk, M.D., Thompson, R.F., 1987. Retention of classically conditioned eyelid responses following acute decerebration. *Brain Research* 403, 89–95.
- McCormick, D.A., Bal, T., 1997. Sleep and arousal: thalamocortical mechanisms. *Annual Review of Neuroscience* 20, 185–215.
- Mechawar, N., Descarries, L., 2001. The cholinergic innervation develops early and rapidly in the rat cerebral cortex: a quantitative immunocytochemical study. *Neuroscience* 108, 555–567.
- Menzel, R.R., Barth, D.S., 2005. Multisensory and secondary somatosensory cortex in the rat. *Cerebral Cortex* 15, 1690–1696.
- Meyer, H.S., Wimmer, V.C., Hemberger, M., Bruno, R.M., de Kock, C.P., Frick, A., Sakmann, B., Helmstaedter, M., 2010. Cell type-specific thalamic innervation in a column of rat vibrissal cortex. *Cerebral Cortex* 20, 2287–2303.
- Minlebaev, M., Ben-Ari, Y., Khazipov, R., 2007. Network mechanisms of spindle-burst oscillations in the neonatal rat barrel cortex in vivo. *Journal of Neurophysiology* 97, 692–700.
- Minlebaev, M., Colonnese, M., Tsintsadze, T., Sirota, A., Khazipov, R., 2011. Early gamma oscillations synchronize developing thalamus and cortex. *Science* 334, 226–229.
- Minnery, B.S., Simons, D.J., 2003. Response properties of whisker-associated trigeminothalamic neurons in rat nucleus principalis. *Journal of Neurophysiology* 89, 40–56.
- Miyashita, T., Feldman, D.E., 2012. Behavioral detection of passive whisker stimuli requires somatosensory cortex. *Cerebral Cortex*, <http://dx.doi.org/10.1093/cercor/bhs155>.
- Moore, C.I., Nelson, S.B., 1998. Spatio-temporal subthreshold receptive fields in the vibrissa representation of rat primary somatosensory cortex. *Journal of Neurophysiology* 80, 2882–2892.
- Murayama, M., Perez-Garci, E., Nevian, T., Bock, T., Senn, W., Larkum, M.E., 2009. Dendritic encoding of sensory stimuli controlled by deep cortical inhibitory neurons. *Nature* 457, 1137–1141.
- Nagai, T., Yamada, S., Tominaga, T., Ichikawa, M., Miyawaki, A., 2004. Expanded dynamic range of fluorescent indicators for Ca<sup>2+</sup> by circularly permuted yellow fluorescent proteins. *Proceedings of the National Academy of Science USA* 101, 10554–10559.
- Neafsey, E.J., Bold, E.L., Haas, G., Hurley-Gius, K.M., Quirk, G., Sievert, C.S., Terrence, R.R., 1986. The organization of the rat motor cortex: a microstimulation mapping study. *Brain Research Reviews* 11, 77–96.
- Neimark, M.A., Andermann, M.L., Hopfield, J.J., Moore, C.I., 2003. Vibrissa resonance as a transduction mechanism for tactile encoding. *Journal of Neuroscience* 23, 6499–6509.
- Nimmervoll, B., White, R., Yang, J.W., An, S., Henn, C., Sun, J.J., Luhmann, H.J., 2012. LPS-induced microglial secretion of TNF-alpha increases activity-dependent neuronal apoptosis in neonatal cerebral cortex. *Cerebral Cortex*, <http://dx.doi.org/10.1093/cercor/bhs156>.
- Oberlaender, M., Boudewijns, Z.S.R.M., Kleele, T., Mansvelter, H.D., Sakmann, B., de Kock, C.P.J., 2011a. Three-dimensional axon morphologies of individual layer 5 neurons indicate cell type-specific intracortical pathways for whisker motion and touch. *Proceedings of the National Academy of Science USA* 108, 4188–4193.
- Oberlaender, M., de Kock, C.P.J., Bruno, R.M., Ramirez, A., Meyer, H.S., Dercksen, V.J., Helmstaedter, M., Sakmann, B., 2011b. Cell type-specific three-dimensional structure of thalamocortical circuits in a column of rat vibrissal cortex. *Cerebral Cortex*, <http://dx.doi.org/10.1093/cercor/bhr317>.
- Oberlaender, M., de Kock, C.P., Bruno, R.M., Ramirez, A., Meyer, H.S., Dercksen, V.J., Helmstaedter, M., Sakmann, B., 2012. Cell type-specific three-dimensional structure of thalamocortical circuits in a column of rat vibrissal cortex. *Cerebral Cortex* 22, 2375–2391.
- O'Connor, D.H., Clack, N.G., Huber, D., Komiyama, T., Myers, E.W., Svoboda, K., 2010a. Vibrissa-based object localization in head-fixed mice. *Journal of Neuroscience* 30, 1947–1967.
- O'Connor, D.H., Huber, D., Svoboda, K., 2009. Reverse engineering the mouse brain. *Nature* 461, 923–929.
- O'Connor, D.H., Peron, S.P., Huber, D., Svoboda, K., 2010b. Neural activity in barrel cortex underlying vibrissa-based object localization in mice. *Neuron* 67, 1048–1061.
- Ohno, S., Kuramoto, E., Furuta, T., Hioki, H., Tanaka, Y.R., Fujiyama, F., Sonomura, T., Uemura, M., Sugiyama, K., Kaneko, T., 2011. A morphological analysis of thalamocortical axon fibers of rat posterior thalamic nuclei: a single neuron tracing study with viral vectors. *Cerebral Cortex*, <http://dx.doi.org/10.1093/cercor/bhr356>.
- Okun, M., Naim, A., Lampl, I., 2010. The subthreshold relation between cortical local field potential and neuronal firing unveiled by intracellular recordings in awake rats. *Journal of Neuroscience* 30, 4440–4448.
- Olah, S., Fule, M., Komlosi, G., Varga, C., Baldi, R., Barzo, P., Tamás, G., 2009. Regulation of cortical microcircuits by unitary GABA-mediated volume transmission. *Nature* 461, 1278–1281.
- Oldford, E., Castro-Alamancos, M.A., 2003. Input-specific effects of acetylcholine on sensory and intracortical evoked responses in the 'barrel cortex' in vivo. *Neuroscience* 117, 769–778.
- Olsen, S.R., Bortone, D.S., Adesnik, H., Scanziani, M., 2012. Gain control by layer six in cortical circuits of vision. *Nature* 483, 47–52.
- Owens, D.F., Kriegstein, A.R., 2002. Is there more to GABA than synaptic inhibition? *Nature Reviews Neuroscience* 3, 715–727.
- Parker, A.J., Newsome, W.T., 1998. Sense and the single neuron: probing the physiology of perception. *Annual Review of Neuroscience* 21, 227–277.
- Paxinos, G., Franklin, K.B.J., 2001. The mouse brain in stereotaxic coordinates. Academic Press, San Diego.
- Petersen, C.C., 2007. The functional organization of the barrel cortex. *Neuron* 56, 339–355.
- Petersen, C.C., Grinvald, A., Sakmann, B., 2003a. Spatiotemporal dynamics of sensory responses in layer 2/3 of rat barrel cortex measured in vivo by voltage-sensitive dye imaging combined with whole-cell voltage recordings and neuron reconstructions. *Journal of Neuroscience* 23, 1298–1309.
- Petersen, C.C., Hahn, T.T., Mehta, M., Grinvald, A., Sakmann, B., 2003b. Interaction of sensory responses with spontaneous depolarization in layer 2/3 barrel cortex. *Proceedings of the National Academy of Science USA* 100, 13638–13643.
- Petersen, C.C., Sakmann, B., 2000. The excitatory neuronal network of rat layer 4 barrel cortex. *Journal of Neuroscience* 20, 7579–7586.
- Petreanu, L., Gutnisky, D.A., Huber, D., Xu, N.L., O'Connor, D.H., Tian, L., Looger, L., Svoboda, K., 2012. Activity in motor-sensory projections reveals distributed coding in somatosensation. *Nature* 489, 299–303.
- Petreanu, L., Huber, D., Sobczyk, A., Svoboda, K., 2007. Channelrhodopsin-2-assisted circuit mapping of long-range callosal projections. *Nature Neuroscience* 10, 663–668.
- Petreanu, L., Mao, T., Sternson, S.M., Svoboda, K., 2009. The subcellular organization of neocortical excitatory connections. *Nature* 457, 1142–1145.
- Pichon, F., Nikonenko, I., Kraftsik, R., Welker, E., 2012. Intracortical connectivity of layer VI pyramidal neurons in the somatosensory cortex of normal and barrel-less mice. *European Journal of Neuroscience* 35, 855–869.
- Pierret, T., Lavallée, P., Deschênes, M., 2000. Parallel streams for the relay of vibrissal information through thalamic barreloids. *Journal of Neuroscience* 20, 7455–7462.
- Pinto, D.J., Hartings, J.A., Brumberg, J.C., Simons, D.J., 2003. Cortical damping: analysis of thalamocortical response transformations in rodent barrel cortex. *Cerebral Cortex* 13, 33–44.
- Porter, J.T., Cauli, B., Staiger, J.F., Lambolez, B., Rossier, J., Audinat, E., 1998. Properties of bipolar VIPergic inhibitory neurons and their excitation by pyramidal neurons in the rat neocortex. *European Journal of Neuroscience* 10, 3617–3628.
- Porter, J.T., Cauli, B., Tsuzuki, K., Lambolez, B., Rossier, J., Audinat, E., 1999. Selective excitation of subtypes of neocortical inhibitory neurons by nicotinic receptors. *Journal of Neuroscience* 19, 5228–5235.
- Porter, J.T., Johnson, C.K., Agmon, A., 2001. Diverse types of inhibitory neurons generate thalamus-evoked feedforward inhibition in the mouse barrel cortex. *Journal of Neuroscience* 21, 2699–2710.
- Poulet, J.F.A., Fernandez, L.M., Crochet, S., Petersen, C.C., 2012. Thalamic control of cortical states. *Nature Neuroscience* 15, 370–372.
- Poulet, J.F.A., Petersen, C.C., 2008. Internal brain state regulates membrane potential synchrony in barrel cortex of behaving mice. *Nature* 454, 881–885.

- Ramanathan, D., Tuszyński, M.H., Conner, J.M., 2009. The basal forebrain cholinergic system is required specifically for behaviorally mediated cortical map plasticity. *Journal of Neuroscience* 29, 5992–6000.
- Ramon, Cajal, S., 1921. Textura de la corteza visual del gato translation in: Cajal on the cerebral cortex. *Archivos de Neurobiología* 2, 338–362.
- Rash, B.G., Grove, E.A., 2006. Area and layer patterning in the developing cerebral cortex. *Current Opinion in Neurobiology* 16, 25–34.
- Recanzone, G.H., Merzenich, M.M., Jenkins, W.M., Grajski, K.A., Dinse, H.R., 1992. Topographic reorganization of the hand representation in cortical area 3b owl monkeys trained in a frequency-discrimination task. *Journal of Neurophysiology* 67, 1031–1056.
- Recanzone, G.H., Schreiner, C.E., Merzenich, M.M., 1993. Plasticity in the frequency representation of primary auditory cortex following discrimination training in adult owl monkeys. *Journal of Neuroscience* 13, 87–103.
- Remple, M.S., Henry, E.C., Catania, K.C., 2003. Organization of somatosensory cortex in the laboratory rat (*Rattus norvegicus*): Evidence for two lateral areas joined at the representation of the teeth. *Journal of Comparative Neurology* 467, 105–118.
- Reyes, A., Lujan, R., Rozov, A., Burnashev, N., Somogyi, P., Sakmann, B., 1998. Target-cell-specific facilitation and depression in neocortical circuits. *Nature Neuroscience* 1, 279–285.
- Rodgers, K.M., Benison, A.M., Klein, A., Barth, D.S., 2008. Auditory, somatosensory, and multisensory insular cortex in the rat. *Cerebral Cortex* 18, 2941–2951.
- Rowell, J.J., Mallik, A.K., Dugas-Ford, J., Ragsdale, C.W., 2010. Molecular analysis of neocortical layer structure in the ferret. *Journal of Comparative Neurology* 518, 3272–3289.
- Rozov, A., Jeretic, J., Sakmann, M.B., Burnashev, N., 2001. AMPA receptor channels with long-lasting desensitization in bipolar inhibitory neurons contribute to synaptic depression in a novel feedback circuit in layer 2/3 of rat neocortex. *Journal of Neuroscience* 21, 8062–8071.
- Rudy, B., Fishell, G., Lee, S., Hjerling-Leffler, J., 2011. Three groups of interneurons account for nearly 100% of neocortical GABAergic neurons. *Developmental Neurobiology* 71, 45–61.
- Sanchez-Jimenez, A., Panetsos, F., Murciano, A., 2009. Early frequency-dependent information processing and cortical control in the whisker pathway of the rat: electrophysiological study of brainstem nuclei principalis and interpolaris. *Neuroscience* 160, 212–226.
- Sato, T.R., Gray, N.W., Mainen, Z.F., Svoboda, K., 2007. The functional microarchitecture of the mouse barrel cortex. *PLoS Biology* 5, e189.
- Sato, T.R., Svoboda, K., 2010. The functional properties of barrel cortex neurons projecting to the primary motor cortex. *Journal of Neuroscience* 30, 4256–4260.
- Sawinski, J., Wallace, D.J., Greenberg, D.S., Grossmann, S., Denk, W., Kerr, J.N., 2009. Visually evoked activity in cortical cells imaged in freely moving animals. *Proceedings of the National Academy of Science USA* 106, 19557–19562.
- Schoups, A., Vogels, R., Qian, N., Orban, G., 2001. Practising orientation identification improves orientation coding in V1 neurons. *Nature* 412, 549–553.
- Schubert, D., Kötter, R., Luhmann, H.J., Staiger, J.F., 2006. Morphology, electrophysiology and functional input connectivity of pyramidal neurons characterizes a genuine layer Va in the primary somatosensory cortex. *Cerebral Cortex* 16, 223–236.
- Schubert, D., Kötter, R., Staiger, J.F., 2007. Mapping functional connectivity in barrel-related columns reveals layer- and cell type-specific microcircuits. *Brain Structure and Function* 212, 107–119.
- Schubert, D., Kötter, R., Zilles, K., Luhmann, H.J., Staiger, J.F., 2003. Cell type-specific circuits of cortical layer IV spiny neurons. *Journal of Neuroscience* 23, 2961–2970.
- Schubert, D., Staiger, J.F., Cho, N., Kötter, R., Zilles, K., Luhmann, H.J., 2001. Layer-specific intracolumnar and transcolumnar functional connectivity of layer V pyramidal cells in rat barrel cortex. *Journal of Neuroscience* 21, 3580–3592.
- Schwarz, C., Hentschke, H., Butovas, S., Haiss, F., Stüttgen, M.C., Gerdjikov, T., Bergner, C., Waiblinger, C., 2010. The head-fixed behaving rat – procedures and pitfalls. *Somatosensory & Motor Research* 27, 131–148.
- Shepherd, G.M., Svoboda, K., 2005. Laminar and columnar organization of ascending excitatory projections to layer 2/3 pyramidal neurons in rat barrel cortex. *Journal of Neuroscience* 25, 5670–5679.
- Sherman, S.M., Guillery, R.W., 2011. Distinct functions for direct and transthalamic corticocortical connections. *Journal of Neurophysiology* 106, 1068–1077.
- Shi, C.J., Cassell, M.D., 1997. Cortical, thalamic, and amygdaloid projections of rat temporal cortex. *Journal of Comparative Neurology* 382, 153–175.
- Silberberg, G., Markram, H., 2007. Disynaptic inhibition between neocortical pyramidal cells mediated by Martinotti cells. *Neuron* 53, 735–746.
- Silver, R.A., Lübke, J., Sakmann, B., Feldmeyer, D., 2003. High-probability unquantal transmission at excitatory synapses in barrel cortex. *Science* 302, 1981–1984.
- Simons, D.J., 1978. Response properties of vibrissa units in rat S1 somatosensory neocortex. *Journal of Neurophysiology* 41, 798–820.
- Simons, D.J., 1985. Temporal and spatial integration in the rat S1 vibrissa cortex. *Journal of Neurophysiology* 54, 615–635.
- Simons, D.J., Carvell, G.E., 1989. Thalamic cortical response transformation in the rat vibrissa/barrel system. *Journal of Neurophysiology* 61, 311–330.
- Simons, D.J., Carvell, G.E., Hershey, A.E., Bryant, D.P., 1992. Responses of barrel cortex neurons in awake rats and effects of urethane anesthesia. *Experimental Brain Research* 91, 259–272.
- Skoglund, T.S., Pascher, R., Berthold, C.H., 1997. The existence of a layer IV in the rat motor cortex. *Cerebral Cortex* 7, 178–180.
- Staiger, J.F., Flagmeyer, I., Schubert, D., Zilles, K., Kötter, R., Luhmann, H.J., 2004. Functional diversity of layer IV spiny neurons in rat somatosensory cortex: quantitative morphology of electrophysiologically characterized and biocytin labeled cells. *Cerebral Cortex* 14, 690–701.
- Staiger, J.F., Zilles, K., Freund, T.F., 1996. Distribution of GABAergic elements postsynaptic to ventroposteromedial thalamic projections in layer IV of rat barrel cortex. *European Journal of Neuroscience* 8, 2273–2285.
- Staiger, J.F., Zuschratter, W., Luhmann, H.J., Schubert, D., 2009. Local circuits targeting parvalbumin-containing inhibitory neurons in layer IV of rat barrel cortex. *Brain Structure and Function* 214, 1–13.
- Stratford, K.J., Tarczy-Hornoch, K., Martin, K.A.C., Bannister, N.J., Jack, J.J.B., 1996. Excitatory synaptic inputs to spiny stellate cells in cat visual cortex. *Nature* 382, 258–261.
- Stüttgen, M.C., Rüter, J., Schwarz, C., 2006. Two psychophysical channels of Whisker deflection in rats align with two neuronal classes of primary afferents. *Journal of Neuroscience* 26, 7933–7941.
- Stüttgen, M.C., Schwarz, C., 2008. Psychophysical and neurometric detection performance under stimulus uncertainty. *Nature Neuroscience* 11, 1091–1099.
- Stüttgen, M.C., Schwarz, C., 2010. Integration of vibrotactile signals for whisker-related perception in rats is governed by short time constants: comparison of neurometric and psychometric detection performance. *Journal of Neuroscience* 30, 2060–2069.
- Sugino, K., Hempel, C.M., Miller, M.N., Hattox, A.M., Shapiro, P., Wu, C., Huang, Z.J., Nelson, S.B., 2006. Molecular taxonomy of major neuronal classes in the adult mouse forebrain. *Nature Neuroscience* 9, 99–107.
- Sun, J.J., Luhmann, H.J., 2007. Spatio-temporal dynamics of oscillatory network activity in the neonatal mouse cerebral cortex. *European Journal of Neuroscience* 26, 1995–2004.
- Sun, Q.Q., 2009. Experience-dependent intrinsic plasticity in inhibitory neurons of barrel cortex layer IV. *Journal of Neurophysiology* 102, 2955–2973.
- Sun, Q.Q., Huguenard, J.R., Prince, D.A., 2006. Barrel cortex microcircuits: thalamo-cortical feedforward inhibition in spiny stellate cells is mediated by a small number of fast-spiking inhibitory neurons. *Journal of Neuroscience* 26, 1219–1230.
- Sur, M., Leamey, C.A., 2001. Development and plasticity of cortical areas and networks. *Nature Reviews Neuroscience* 2, 251–262.
- Swadlow, H.A., 1988. Efferent neurons and suspected interneurons in binocular visual cortex of the awake rabbit: receptive fields and binocular properties. *Journal of Neurophysiology* 59, 1162–1187.
- Swadlow, H.A., 1989. Efferent neurons and suspected interneurons in S-1 vibrissa cortex of the awake rabbit: receptive fields and axonal properties. *Journal of Neurophysiology* 62, 288–308.
- Swadlow, H.A., 1990. Efferent neurons and suspected interneurons in S-1 forelimb representation of the awake rabbit: receptive fields and axonal properties. *Journal of Neurophysiology* 63, 1477–1498.
- Swadlow, H.A., 1991. Efferent neurons and suspected interneurons in second somatosensory cortex of the awake rabbit: receptive fields and axonal properties. *Journal of Neurophysiology* 66, 1392–1409.
- Swadlow, H.A., 1994. Efferent neurons and suspected interneurons in motor cortex of the awake rabbit: axonal properties, sensory receptive fields, and subthreshold synaptic inputs. *Journal of Neurophysiology* 71, 437–453.
- Tan, Z., Hu, H., Huang, Z.J., Agmon, A., 2008. Robust but delayed thalamocortical activation of dendritic-targeting inhibitory neurons. *Proceedings of the National Academy of Science USA* 105, 2187–2192.
- Taniguchi, H., He, M., Wu, P., Kim, S., Paik, R., Sugino, K., Kvitsani, D., Fu, Y., Lu, J.T., Lin, Y., Miyoshi, G., Shima, Y., Fishell, G., Nelson, S.B., Huang, Z.J., 2011. A resource of Cre driver lines for genetic targeting of GABAergic neurons in cerebral cortex. *Neuron* 71, 995–1013.
- Tarczy-Hornoch, K., Martin, K.A.C., Stratford, K.J., Jack, J.J.B., 1999. Intracortical excitation of spiny neurons in layer 4 of cat striate cortex *in vitro*. *Cerebral Cortex* 9, 833–843.
- Theyel, B.B., Llano, D.A., Sherman, S.M., 2010. The corticothalamic circuit drives higher-order cortex in the mouse. *Nature Neuroscience* 13, 84–88.
- Thomson, A.M., 2010. Neocortical layer 6, a review. *Frontiers in Neuroanatomy* 4, 13.
- Tian, L., Hires, S.A., Mao, T., Huber, D., Chiappe, M.E., Chalasani, S.H., Petreanu, L., Akerboom, J., McKinney, S.A., Schreiner, E.R., Bargmann, C.L., Jayaraman, V., Svoboda, K., Looger, L.L., 2009. Imaging neural activity in worms, flies and mice with improved GCaMP calcium indicators. *Nature Methods* 6, 875–881.
- Timofeeva, E., Lavallee, P., Arsenault, D., Deschênes, M., 2004. Synthesis of multi-whisker-receptive fields in subcortical stations of the vibrissa system. *Journal of Neurophysiology* 91, 1510–1515.
- Trageser, J.C., Keller, A., 2004. Reducing the uncertainty: gating of peripheral inputs by zona incerta. *Journal of Neuroscience* 24, 8911–8915.
- Trageser, J.C., Burke, K.A., Masri, R., Li, Y., Sellers, L., Keller, A., 2006. State-dependent gating of sensory inputs by zona incerta. *Journal of Neurophysiology* 96, 1456–1463.
- Urbain, N., Deschênes, M., 2007. Motor cortex gates vibrissal responses in a thalamocortical projection pathway. *Neuron* 56, 714–725.
- Uylings, H.B., Groenewegen, H.J., Kolb, B., 2003. Do rats have a prefrontal cortex? *Behavioural Brain Research* 146, 3–17.
- Veinante, P., Deschênes, M., 1999. Single- and multi-whisker channels in the ascending projections from the principal trigeminal nucleus in the Rat [In Process Citation]. *Journal of Neuroscience* 19, 5085–5095.
- Veinante, P., Jaquin, M., Deschênes, M., 2000a. Thalamic projections from the whisker sensitive regions of the spinal trigeminal complex in the rat. *Journal of Comparative Neurology* 420, 233–240.



- Veinante, P., Lavallée, P., Deschênes, M., 2000b. Corticothalamic projections from layer 5 of the vibrissal barrel cortex in the rat. *Journal of Comparative Neurology* 424, 197–204.
- von Heimendahl, M., Itskov, P.M., Arabzadeh, E., Diamond, M.E., 2007. Neuronal activity in rat barrel cortex underlying texture discrimination. *PLoS Biology* 5, e305.
- Wagner-Golbs, A., Luhmann, H.J., 2012. Activity-dependent survival of developing neocortical neurons depends on PI3K signalling. *Journal of Neurochemistry* 120, 495–501.
- Waiblinger, C., Brugger, D., Schwarz, C., 2011. Physical cues used for discrimination of vibrotactile signals in the rat vibrissal system. *Society for Neuroscience (Program No. 704.09)*.
- Wallace, D.J., Borgloh, S.M.Z.A., Astori, S., Yang, Y., Bausen, M., Kugler, S., Palmer, A.E., Tsien, R.Y., Sprengel, R., Kerr, J.N.D., Denk, W., Hasan, M.T., 2008. Single-spike detection in vitro and in vivo with a genetic Ca<sup>2+</sup> sensor. *Nature Methods* 5, 797–804.
- Wang, Q., Webber, R.M., Stanley, G.B., 2010. Thalamic synchrony and the adaptive gating of information flow to cortex. *Nature Neuroscience* 13, 1534–1541.
- Waters, J., Helmchen, F., 2006. Background synaptic activity is sparse in neocortex. *Journal of Neuroscience* 26, 8267–8277.
- Webber, R.M., Stanley, G.B., 2004. Nonlinear encoding of tactile patterns in the barrel cortex. *Journal of Neurophysiology* 91, 2010–2022.
- Weiss, C., Weible, A.P., Galvez, R., Disterhoft, J.F., 2006. Forebrain-cerebellar interactions during learning. *Cell Science Review* 3, 200–230.
- Welker, C., 1976. Receptive fields of barrels in the somatosensory neocortex of the rat. *Journal of Comparative Neurology* 166, 173–190.
- Welker, E., Armstrong-James, M., Van der Loos, H., Kraftsik, R., 1993. The mode of activation of a barrel column: response properties of single units in the somatosensory cortex of the mouse upon whisker deflection. *European Journal of Neuroscience* 5, 691–712.
- West, D.C., Mercer, A., Kirchhecker, S., Morris, O.T., Thomson, A.M., 2006. Layer 6 cortico-thalamic pyramidal cells preferentially innervate inhibitory neurons and generate facilitating EPSPs. *Cerebral Cortex* 16, 200–211.
- White, E.L., 1978. Identified neurons in mouse Sml cortex which are postsynaptic to thalamocortical axon terminals: a combined Golgi-electron microscopic and degeneration study. *The Journal of Comparative Neurology* 181, 627–661.
- Wimmer, V.C., Bruno, R.M., de Kock, C.P., Kuner, T., Sakmann, B., 2010. Dimensions of a projection column and architecture of VPM and POM axons in rat vibrissal cortex. *Cerebral Cortex* 20, 2265–2276.
- Witter, M.P., Groenewegen, H.J., Lopes da Silva, F.H., Lohman, A.H.M., 1986. Functional organization of the extrinsic and intrinsic circuitry of the parahippocampal region. *Progress in Neurobiology* 33, 161–253.
- Wolfe, J., Hill, D.N., Pahlavan, S., Drew, P.J., Kleinfeld, D., Feldman, D.E., 2008. Texture coding in the rat whisker system: slip-stick versus differential resonance. *PLoS Biology* 6, e215.
- Wright, N., Fox, K., 2010. Origins of cortical layer V surround receptive fields in the rat barrel cortex. *Journal of Neurophysiology* 103, 709–724.
- Wu, M.C.K., David, S.V., Gallant, J.L., 2006. Complete functional characterization of sensory neurons by system identification. *Annual Review of Neuroscience* 29, 477–505.
- Xu, X., Callaway, E.M., 2009. Laminar specificity of functional input to distinct types of inhibitory cortical neurons. *Journal of Neuroscience* 29, 70–85.
- Xu, X., Roby, K.D., Callaway, E.M., 2010. Immunochemical characterization of inhibitory mouse cortical neurons: three chemically distinct classes of inhibitory cells. *Journal of Comparative Neurology* 518, 389–404.
- Yang, J.W., Hanganu-Opatz, I.L., Sun, J.J., Luhmann, H.J., 2009. Three patterns of oscillatory activity differentially synchronize developing neocortical networks *in vivo*. *Journal of Neuroscience* 29, 9011–9025.
- Yuste, R., Peinado, A., Katz, L.C., 1992. Neuronal domains in developing neocortex. *Science* 257, 665–669.
- Zhang, Z.W., Deschênes, M., 1997. Intracortical axonal projections of lamina VI cells of the primary somatosensory cortex in the rat: a single-cell labeling study. *Journal of Neuroscience* 17, 6365–6379.
- Zhang, Z.W., Deschênes, M., 1998. Projections to layer VI of the posteromedial barrel field in the rat: a reappraisal of the role of corticothalamic pathways. *Cerebral Cortex* 8, 428–436.
- Zhu, J.J., 2000. Maturation of layer 5 neocortical pyramidal neurons: amplifying salient layer 1 and layer 4 inputs by Ca<sup>2+</sup> action potentials in adult rat tuft dendrites. *Journal of Physiology (London)* 526, 571–587.
- Zhu, J.J., Connors, B.W., 1999. Intrinsic firing patterns and whisker-evoked synaptic responses of neurons in the rat barrel cortex. *Journal of Neurophysiology* 81, 1171–1183.
- Zhu, X.O., de Permentier, P.J., Waite, P.M., 2002. Cholinergic depletion by IgG192-saporin retards development of rat barrel cortex. *Brain Research. Developmental Brain Research* 136, 1–16.
- Zhu, X.O., Waite, P.M., 1998. Cholinergic depletion reduces plasticity of barrel field cortex. *Cerebral Cortex* 8, 63–72.